



CATALOG OF

REPLACEMENT PARTS



MODELS M802 & V1401 SERIES MIXERS

(INCLUDES MOTOR PARTS)

ML-104687	M802
ML-104694	M802 (14" Higher Than Standard)
ML-104696	M802U
ML-104674	V1401
ML-104686	V1401 (17" Higher Than Standard)
ML-104683	V1401U

Table of Contents

Page	Description
3	Attachment Hub Unit
5	Switch Plate and Timer Unit
7	Electrical Unit
9	Base and Pedestal Unit (M802 Series)
11	Base and Pedestal Unit (V1401 Series)
13	Shifting Unit
14	Motor Unit (M802 Series)
15	Motor Unit (V1401 Series)
17	Transmission Case Unit
19	Bowl Support Unit (M802 Series)
21	Bowl Support Unit (V1401 Series)
22	Transmission Gear Unit (M802 Series)
24	Transmission Gear Unit (V1401 Series)
26	Clutch and Brake Unit (M802 Series)
28	Clutch and Brake Unit (V1401 Series)
30	Power Bowl Lift Unit
33	Planetary Unit (M802 Series)
35	Planetary Unit (V1401 Series)
37	Bowl Guard Unit
39	Bowls and Equipment (M802 Series)
41	Bowl and Equipment (V1401 Series)
42	Agitators (M802 Series)
43	Agitators (V1401 Series)

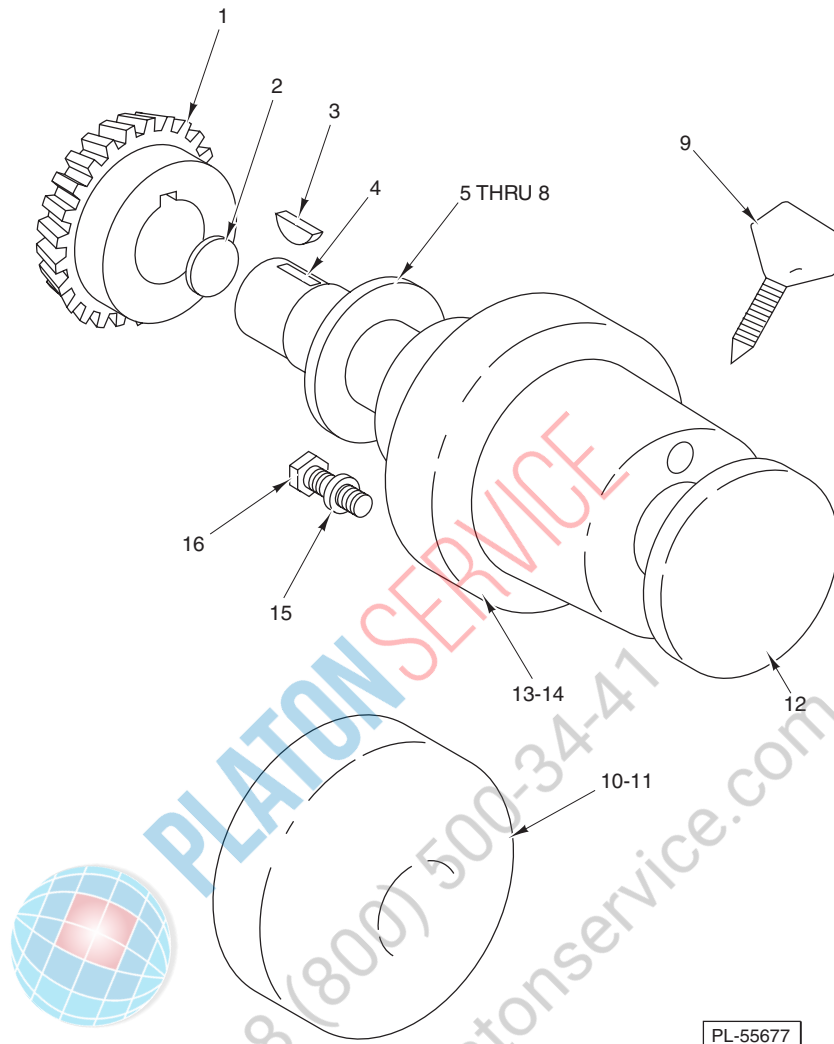

PL-55677

ATTACHMENT HUB UNIT

ILLUS.	PART NO.	NAME OF PART	AMT.
1	00-064422-00002	Bevel Pinion (Attach.) (21T)	1
2	PL-003-22	Plug 1 ¹ / ₈ Expansion	1
3	KW-003-15	Key - Woodruff #807	1
4	00-291679	Sleeve - Square Drive (#12 Attachment Hub)	1
5	00-011091-00003	Shim - Bevel Pinion (0.056 Thk.)	AR
6	00-011091-00004	Shim - Bevel Pinion (0.062 Thk.)	AR
7	00-011091-00005	Shim - Bevel Pinion (0.080 Thk.)	AR
8	00-011091-00011	Shim - Bevel Pinion (0.074 Thk.)	AR
9	00-108197-00002	Thumb Screw 1/2-12	1
10	00-064612-00005	Cover (Painted) (Plugs Attachment Hub Hole)	1
11	00-064612-00004	Cover (Deluxe) (Plugs Attachment Hub Hole)	1
12	00-114824-00001	Plug - Attachment Hub (Deluxe)	1
13	00-291680-00003	Hub - Attachment (#12 Painted)	1
14	00-291680-00005	Hub - Attachment (#12 Deluxe)	1
15	WL-004-06	Lockwasher 3/8 Light	4
16	SC-110-22	Cap Screw 3/8-16 x 1 1/4 Hex Hd.	4

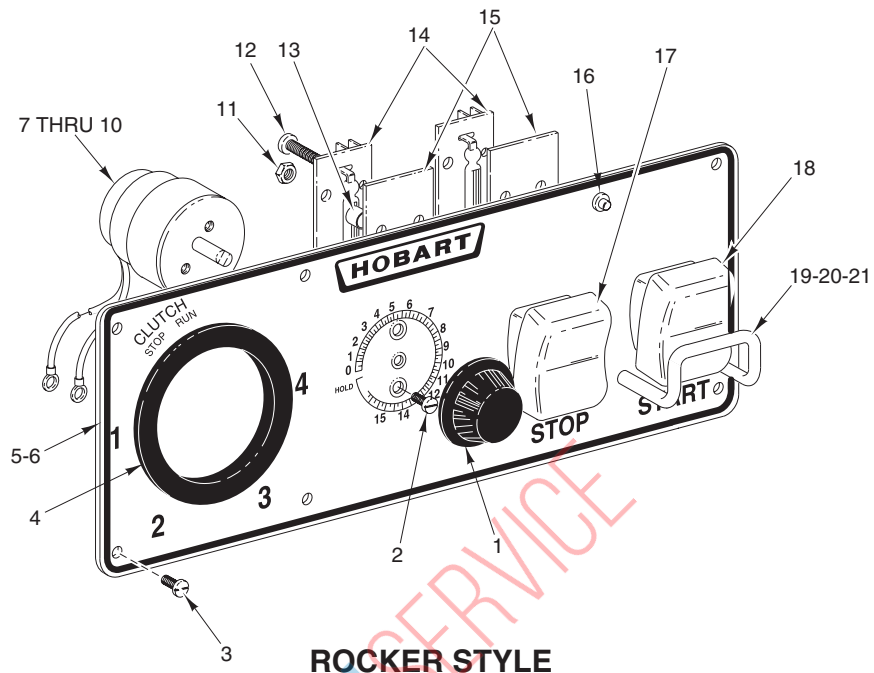

ROCKER STYLE

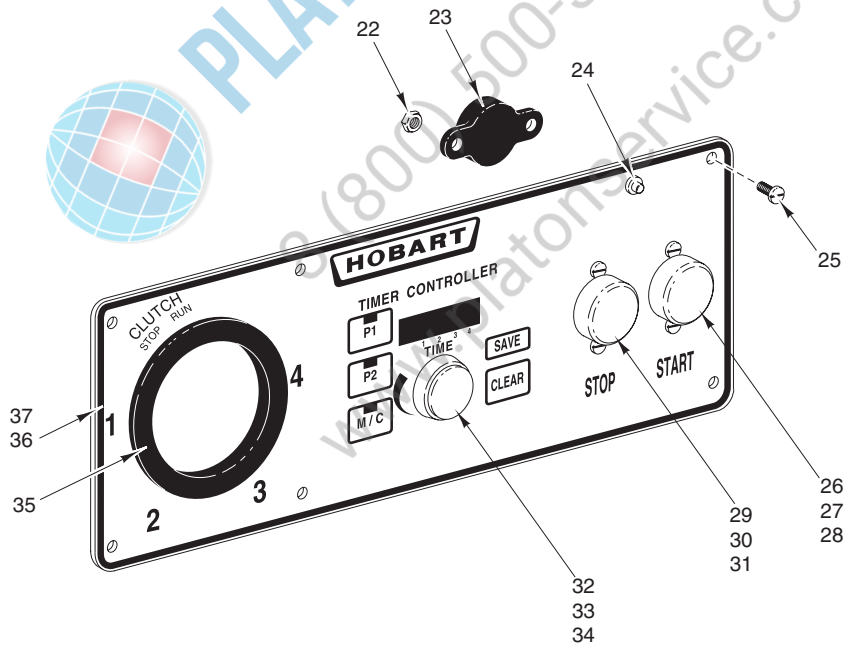

ELECTRONIC

SWITCH PLATE AND TIMER UNIT

PL-56084

SWITCH PLATE AND TIMER UNIT

ILLUS. PL-56084	PART NO.	NAME OF PART	AMT.
1	00-291748	Knob – Timer	1
2	SC-013-07	Mach. Screw 5-40 x 1/4 Flat Hd.	2
3	00-123131	Self-Tapping Screw 8-32 x 3/8 Truss Hd. Taptite	6
4	00-064462	Grommet – Gear Shift Hub	1
5	00-291731-00002	Plate – Switch (Standard Machine)	1
6	00-291733-00002	Plate – Switch (Higher than Standard Machine)	1
7	00-294650-004-1	Timer Assy. (115 V., 60 Hz.)	1
8	00-294650-004-3	Timer Assy. (415 V., 50 Hz.)	1
9	00-294650-004-2	Timer Assy.	1
10	00-291750	Insulator – Switch	1
11	NS-031-01	Stop Nut 6-32 Elastic	4
12	SD-009-40	Self-Tapping Screw 6-32 x 3/4 Phil. Pan Hd., Type F	4
13	00-118349	Standoff – Reed Board (5/16 Lg.)	8
14	00-294854	Reed Mounting Board Assy.	2
15	00-124022	Insulator – Reed Mounting Board	2
16	00-294700-004-2	Pilot Light	1
17	00-120872-00004	Switch – Operator’s Stop	1
18	00-120872-00002	Switch – Operator’s Start	1
19	00-116525	Guard – Switch	1
20	00-123109	Screw 6-32 x 3/8 Serrated Hd.	2
21	WS-002-14	Washer	2
22	NS-046-17	Stop Nut 4-40 Hex	2
23	00-438499-00002	Buzzer	1
24	00-294700-004-2	Pilot Light	1
25	00-123131	Self-Tapping Screw 8-32 x 3/8 Truss Hd. Taptite	6
26	00-087711-183-1	Switch – Push Button	1
27	00-102467-00001	Cap – Push Button (Start) (Black)	1
28	SC-053-38	Mach. Screw 6-32 x 1/4 Truss Hd.	2
29	00-087711-183-2	Switch – Push Button	1
30	00-102467-00002	Cap – Push Button (Stop) (Red)	1
31	SC-053-38	Mach. Screw 6-32 x 1/4 Truss Hd.	2
32	00-439289	Knob – Potentiometer W/Seal Nut	1
33	00-438171	Board – Display	1
34	00-439400-00001	Board (120 V.)	1
35	00-064462	Grommet – Gear Shift Hub	1
36	00-438324-00001	Switch Plate & Keypad Assy. (Standard Machine)	1
37	00-438324-00003	Switch Plate & Keypad Assy. (Higher than Standard)	1

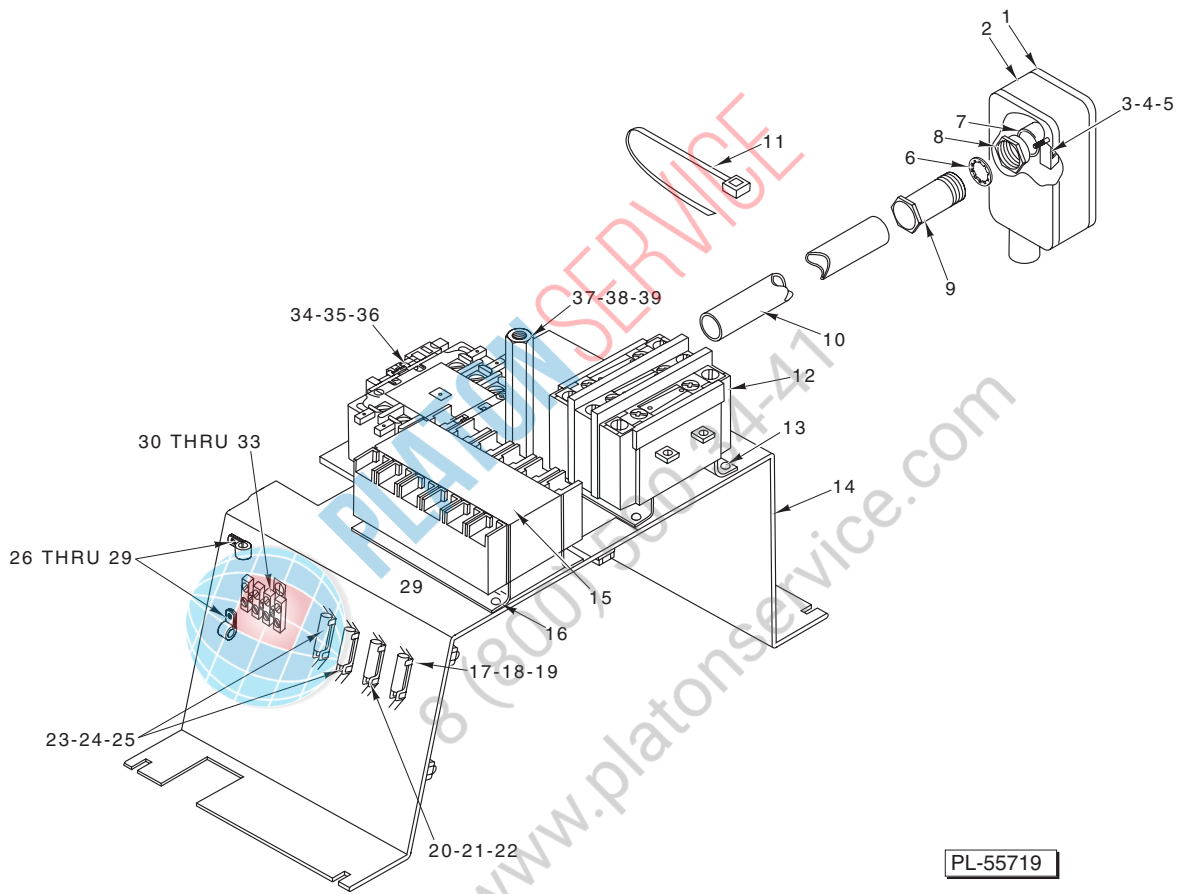

ELECTRICAL UNIT

ELECTRICAL UNIT

ILLUS.	PART NO.	NAME OF PART	AMT.
PL-55719			
1	FE-004-21	Cover – Junction Box	1
2	00-064495	Box – Junction	1
3	00-118544-00001	Lug – Solderless	1
4	SD-024-01	Self-Tapping Screw 10-24 x 3/8 Pan Hd., Type TT	1
5	WL-010-06	Lockwasher #10 External Shakeproof	1
6	WL-019-05	Lockwasher 1 1/8 Internal Shakeproof	1
7	FE-007-14	Bushing 3/4 Conduit	1
8	FE-007-12	Lock Nut 3/4 Conduit	2
9	00-064494	Bushing – Conduit	1
10	00-062336-00078	Conduit 1 x 12 Lg. (Non-Metallic)	1
11	00-113703	Cable Tie	AR
12	00-088196-005-1	Relay	1
13	SD-015-20	Self-Tapping Screw 10-32 x 3/8 Phil. Hd., Type TT	2
14	00-124676	Panel – Control	1
15	00-294500-00034	Transformer	1
16	SD-015-20	Self-Tapping Screw 10-32 x 3/8 Phil. Hd., Type TT	2
17	FE-024-89	Fuse (0.25 Amp.) (250 V.)	1
18	00-294436-00003	Block – Fuse	1
19	SD-015-38	Self-Tapping Screw 6-32 x 3/8 Phil. Hd., Type TT	1
20	FE-025-69	Fuse (0.6 Amp.) (250 V.)	1
21	00-294436-00003	Block – Fuse	1
22	SD-015-38	Self-Tapping Screw 6-32 x 3/8 Phil. Hd., Type TT	1
23	FE-025-68	Fuse (0.2 Amp.) (250 V.)	2
24	00-294436-00003	Block – Fuse	2
25	SD-015-38	Self-Tapping Screw 6-32 x 3/8 Phil. Hd., Type TT	2
26	00-078752-00004	Clamp – Wire	2
27	SC-008-10	Mach. Screw 10-24 x 1/4	2
28	NS-044-09	Nut Assy.	2
29	WL-007-12	Lockwasher #10 External	2
30	00-477562-00002	Block – Terminal	1
31	SC-009-85	Mach. Screw 6-32 x 1 1/4 Rd. Hd.	2
32	WL-019-32	Lockwasher #6 External	2
33	NS-009-07	Mach. Nut 6-32 Hex	2
34	00-087713-101-2	Contactor – 3P 30 Amp./Aux. (115 V.)	1
35	00-087713-101-1	Contactor – 3P 30 Amp./Aux. (200 V.)	1
36	SD-015-20	Self-Tapping Screw 10-32 3/8 Phil. Hd., Type TT	2
37	00-124655	Support – Top Cover	1
38	SC-036-14	Cap Screw 1/4-20 x 1/2 Hex Hd.	1
39	WL-003-38	Lockwasher 1/4 Light	1

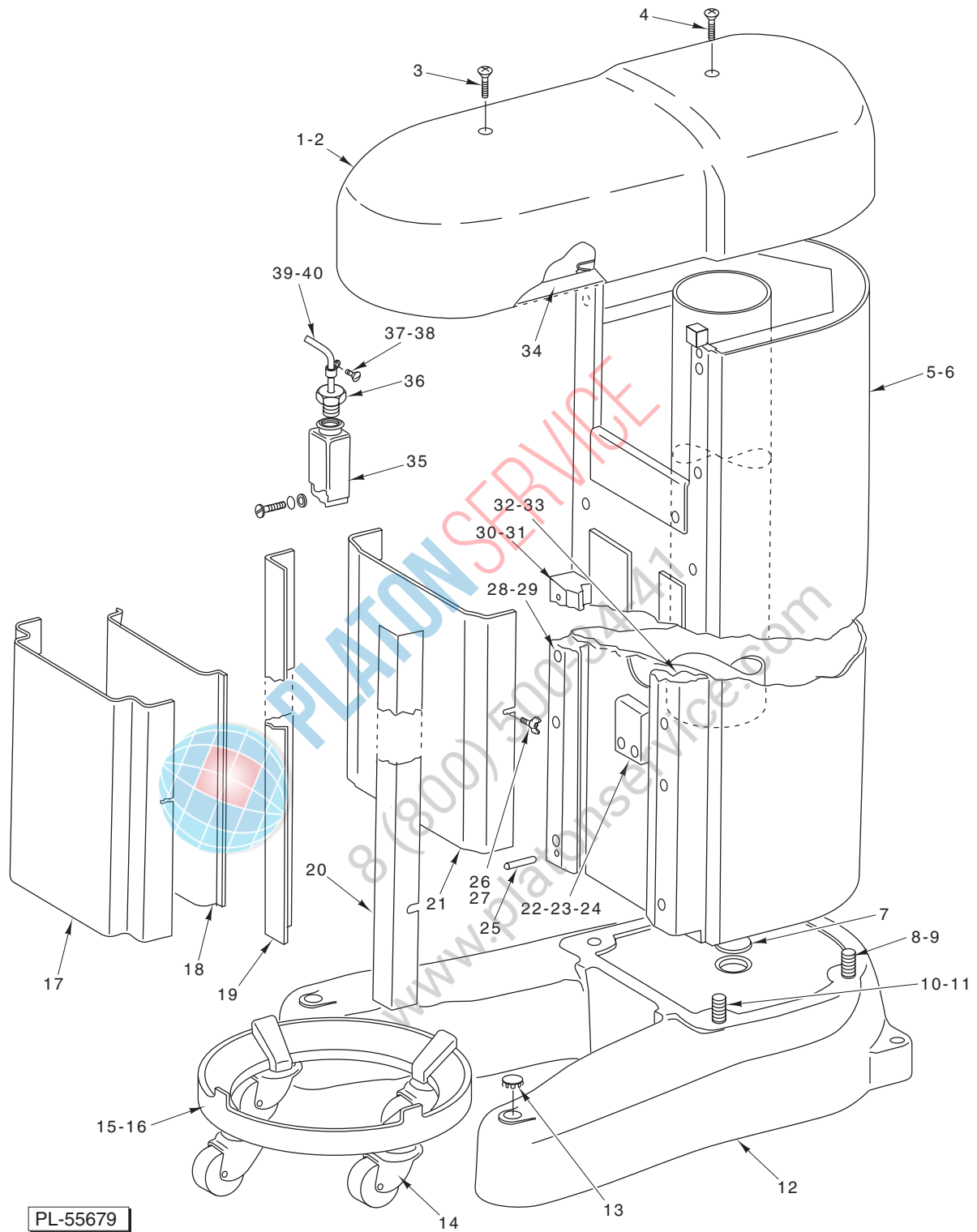

PL-55679

**BASE AND PEDESTAL UNIT
(M802 SERIES)**

**BASE AND PEDESTAL UNIT
(M802 SERIES)**

ILLUS.	PART NO.	NAME OF PART	AMT.
PL-55679			
1	00-478571-00009	Top Cover Assy. (ML-104687 & ML-104694) (Incls. Item 34)	1
2	00-478571-00010	Top Cover Assy. (ML-104696) (Incls. Item 34)	1
3	SC-120-30	Mach. Screw 1/4-20 x 2 Oval Hd.	1
4	SC-120-29	Mach. Screw 1/4-20 x 1 Phil. Oval Hd.	1
5	00-477112-00001	Pedestal Assy. (Std.)	1
6	00-477112-00002	Pedestal Assy. (ML-104694)	1
7	PL-003-39	Plug 2 1/4 Expansion	1
8	SC-037-01	Cap Screw 1/2-13 x 1 1/2 Hex Hd.	2
9	WL-004-36	Lockwasher 1/2 Light	2
10	SC-037-36	Cap Screw 5/8-11 x 3 1/2 Hex Hd.	2
11	WL-004-18	Lockwasher 5/8 Light	2
12	00-064362-00002	Base	1
13	00-072442-00001	Plug – Button (Used to Plug Holes for Hold Down Bolts)	4
14	00-087669-00001	Caster – Bowl Truck	4
15	00-315011	Bowl Truck Assy. (Painted) (Pkg.) (Incls. Item 14)	1
16	00-315013	Bowl Truck Assy. (Aluminum) (Pkg.) (Incls. Item 14)	1
17	00-086502	Outer Apron Assy. (ML-104694)	1
18	00-077495	Apron – Inner (ML-104694)	1
19	00-077497	Cover – Slideway (LH) (ML-104694)	1
20	00-077496	Cover – Slideway (RH) (ML-104694)	1
21	00-064471	Apron (ML-104687)	1
22	00-290407-00001	Block – Stop (ML-104687)	1
23	00-290407-00002	Block – Stop (ML-104694)	1
24	SC-040-69	Cap Screw 1/2-20 x 2 Soc. Fil. Hd.	2
25	00-011800-00143	Dowel	2
26	00-070641-00009	Thumb Screw (ML-104687)	2
27	00-070641-00009	Thumb Screw (ML-104694) (Cover)	4
28	SC-040-69	Cap Screw 1/2-20 x 2 Soc. Fil. Hd.	AR
29	WL-004-13	Lockwasher 1/2 Medium	AR
30	00-479597	Slideway (LH) (ML-104687)	1
31	00-479623	Slideway (LH) (ML-104694)	1
32	00-479598	Slideway (RH) (ML-104687)	1
33	00-479624	Slideway (RH) (ML-104694)	1
34	00-123687-00005	Seat – Top Cover (Rubber)	1
35	00-087711-00249	Limit Switch	1
36	FE-022-84	Strain Relief (Hevco #3231) (Liquid Tight)	1
37	00-078752-00003	Clamp – Cable	1
38	SC-008-41	Mach. Screw 10-32 x 1/2 Rd. Hd.	1
39	00-294853-00016	Cable – Control	1
40	00-270632	Bushing – Snap (Used to Route Cable thru Pedestal Wall)	1

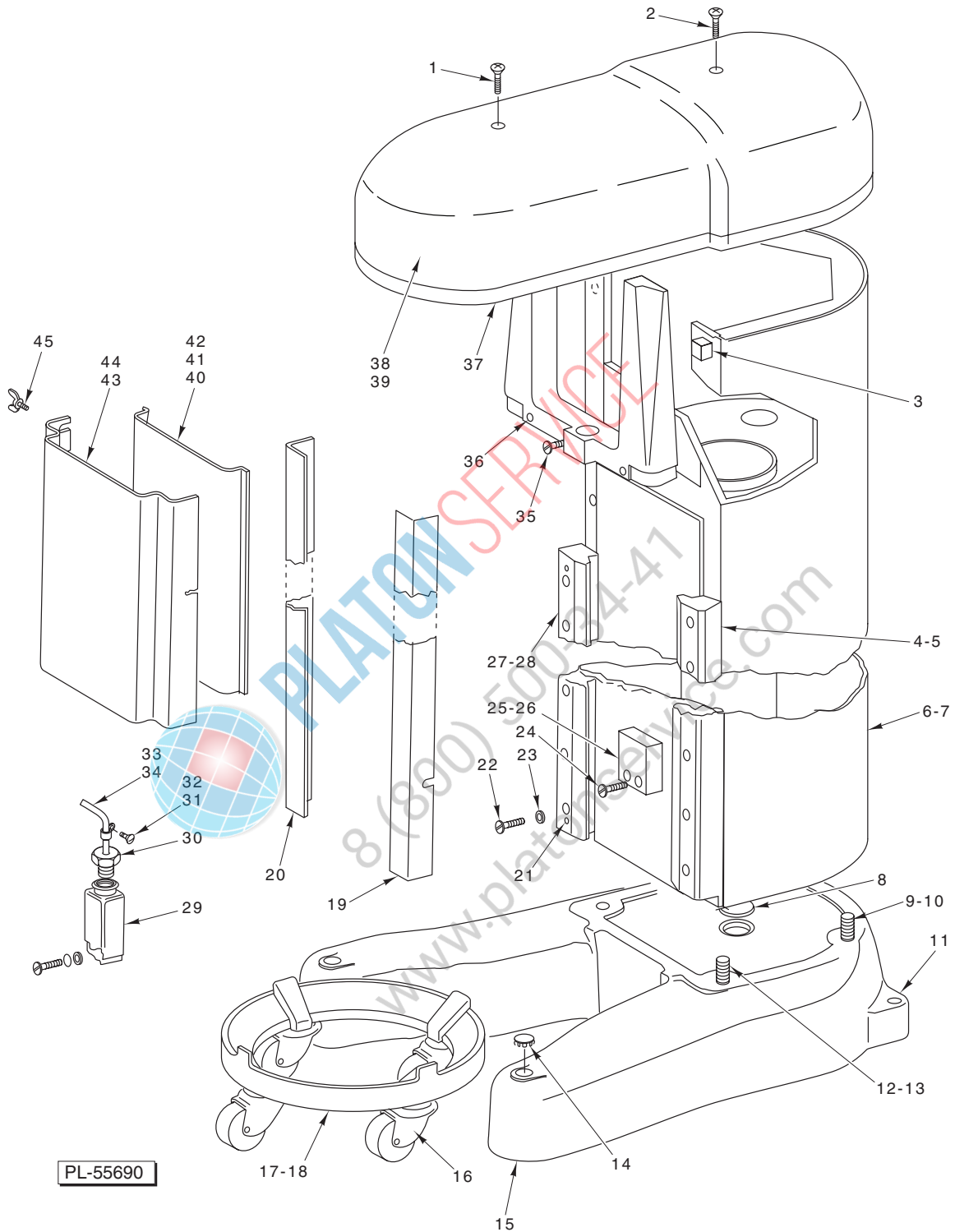

**BASE AND PEDESTAL UNIT
(V1401 SERIES)**

**BASE AND PEDESTAL UNIT
(V1401 SERIES)**

ILLUS. PL-55690	PART NO.	NAME OF PART	AMT.
1	SC-120-30	Mach. Screw 1/4-20 x 2 Oval Hd.	1
2	SC-120-29	Mach. Screw 1/4-20 x 1 Phil. Oval Hd.	1
3	00-011800-00180	Dowel	1
4	00-479626	Slideway (RH) (ML-104674)	1
5	00-479628	Slideway (RH) (ML-104686)	1
6	00-477113-00001	Pedestal Assy. (ML-104674)	1
7	00-477113-00002	Pedestal Assy. (ML-104686)	1
8	PL-003-39	Plug 2 1/4 Expansion	1
9	SC-037-01	Cap Screw 1/2-13 x 1 1/2 Hex Hd.	2
10	WL-006-36	Lockwasher 1/2 Light	2
11	00-072442-00001	Plug – Button (Used to Plug Holes for Hold Down Bolts)	2
12	SC-037-36	Cap Screw 5/8-11 x 3 1/2 Hex Hd.	2
13	WL-004-18	Lockwasher 5/8 Light	2
14	00-072442-00001	Plug – Button (Used to Plug Holes for Hold Down Bolts)	2
15	00-067880-00002	Base	1
16	00-087669-00001	Caster – Bowl Truck	4
17	00-315011	Bowl Truck Assy. (Painted) (Pkg.) (Incls. Item 16)	1
18	00-315013	Bowl Truck Assy. (Aluminum) (Pkg.) (Incls. Item 16)	1
19	00-102151	Slideway Cover Assy. (RH) (ML-104686)	1
20	00-102155	Slideway Cover Assy. (LH) (ML-104686)	1
21	00-011800-00143	Dowel	2
22	SC-040-69	Cap Screw 1/2-20 x 2 Soc. Fil. Hd.	AR
23	WL-004-13	Lockwasher 1/2 Medium	AR
24	SC-040-69	Cap Screw 1/2-20 x 2 Soc. Fil. Hd.	2
25	00-290408-00001	Block – Stop (ML-104674)	1
26	00-290408-00002	Block – Stop (ML-104686) (Not Shown)	1
27	00-479626	Slideway (LH) (ML-104674)	1
28	00-479628	Slideway (LH) (ML-104686)	1
29	00-087711-00249	Limit Switch	1
30	FE-022-84	Strain Relief (Heyco #3231) (Liquid Tight)	1
31	SC-008-41	Mach. Screw 10-32 x 1/2 Rd. Hd.	1
32	00-078752-00003	Clamp – Cable	1
33	00-294853-00016	Cable – Control	1
34	00-270632	Bushing – Snap (Used to Route Cable thru Pedestal Wall)	1
35	SC-040-45	Cap Screw 5/8-11 x 2 Soc. Fil. Hd.	1
36	00-067923-00002	Adapter – Transmission Case	1
37	00-123687-00006	Seat – Top Cover (Rubber)	1
38	00-478571-00011	Top Cover Assy. (Incls. Item 37) (ML-104674 & ML-104686)	1
39	00-478571-00012	Top Cover Assy. (Incls. Item 37) (ML-104683)	1
40	00-291201	Apron – Inner	1
41	SC-010-32	Mach. Screw 8-32 x 3/8 Truss Hd.	2
42	00-102150	Apron – Inner (ML-104686)	1
43	00-067906	Apron (ML-104674)	1
44	00-102147	Apron (ML-104686)	1
45	00-070641-00009	Thumb Screw	4

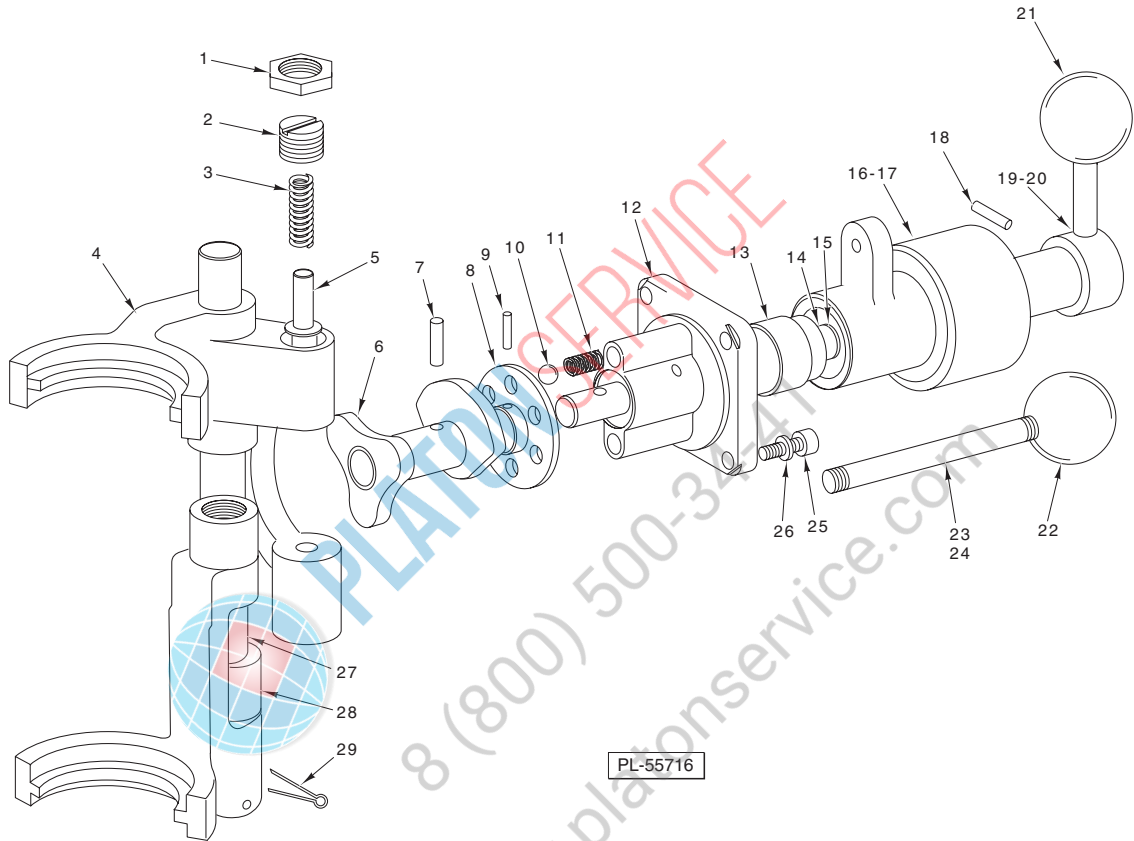

SHIFTING UNIT

SHIFTING UNIT

ILLUS.	PART NO.	NAME OF PART	AMT.
PL-55716			
1	00-024232	Nut – Plunger Screw	3
2	00-060723	Screw – Shifting Plunger	4
3	00-024233	Spring – Shifting Plunger	4
4	00-024229	Yoke – Upper Shifting	1
5	00-024230	Plunger – Shifting Yoke	4
6	00-024249	Gear Shift Cam Assy.	1
7	RP-002-06	Roll Pin 1/4 Dia. x 1 Lg.	1
8	00-061922-00002	Hub and Cam Assy.	1
9	RP-002-10	Roll Pin 3/16 Dia. x 1 Lg.	1
10	BA-002-18	Ball 3/8 Dia.	2
11	00-007009	Spring	2
12	00-064413	Bracket – Gear Shift	1
13	00-119721	Bushing – Clutch Hub	2
14	00-064417	Shaft – Gear Shift	1
15	00-067500-00006	O-Ring	1
16	00-873096-00004	Clutch Handle Hub Assy. (Painted) (Incls. Item 13)	1
17	00-873096-00003	Clutch Handle Hub Assy. (Deluxe) (Incls. Item 13)	1
18	RP-002-10	Roll Pin 3/16 Dia. x 1 Lg.	1
19	00-064553-00005	Gear Shift Handle & Hub Assy. (Painted)	1
20	00-064553-00004	Gear Shift Handle & Hub Assy. (Deluxe)	1
21	00-064645	Knob (Gear Shift)	1
22	00-064645	Knob (Clutch)	1
23	00-064418-00001	Handle – Clutch (Painted)	1
24	00-064418-00003	Handle – Clutch (Deluxe)	1
25	SC-011-93	Mach. Screw 5/16-18 x 3/4 Fil. Hd.	4
26	WL-003-43	Lockwasher 5/16 Light	4
27	00-064830	Shaft – Shifter	1
28	00-024228	Yoke – Lower Shifting	1
29	PC-003-24	Cotter Pin 1/16 x 1 1/2	1

MODELS M802 & V1401 SERIES MIXERS REPLACEMENT PARTS

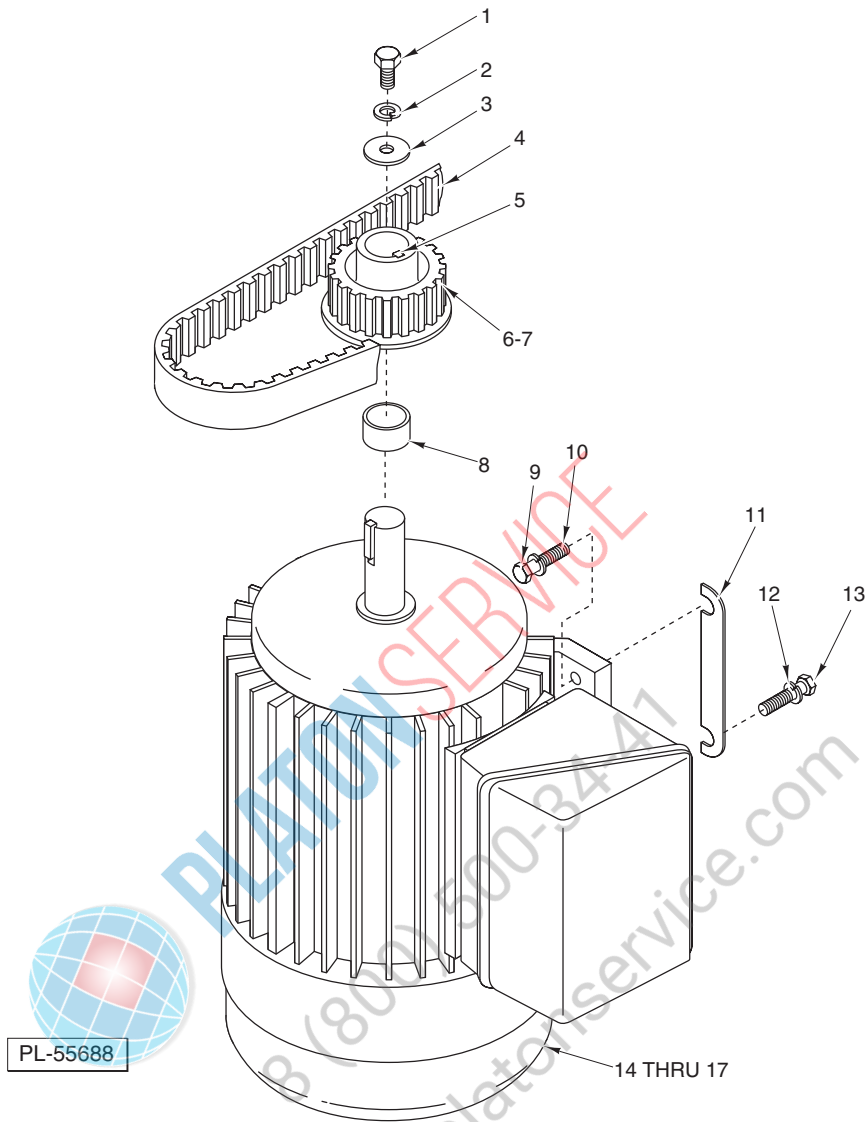

**MOTOR UNIT
(M802 SERIES)**

ILLUS.	PART NO.	NAME OF PART	AMT.
PL-55688			
1	SC-118-60	Cap Screw $\frac{3}{8}$ -16 x $\frac{3}{4}$ Hex Hd.	1
2	WL-004-06	Lockwasher $\frac{3}{8}$ Light	1
3	WS-018-41	Washer	1
4	00-065107	Flexa-Gear	1
5	00-109070-00019	Key - $\frac{1}{4}$ x $\frac{1}{4}$ x $1\frac{1}{2}$	1
6	00-478237	Drive Gear (Flexa-Gear) (24T) (60 Hz.)	1
7	00-478238	Drive Gear (Flexa-Gear) (27T) (50 Hz.)	1
8	00-118816	Spacer	1
9	SC-110-22	Cap Screw $\frac{3}{8}$ -16 x $1\frac{1}{4}$ Hex Hd.	2
10	WL-004-06	Lockwasher $\frac{3}{8}$ Light	2
11	00-478323	Shim - Motor	AR
12	WL-004-06	Lockwasher $\frac{3}{8}$ Light	2
13	SC-036-60	Cap Screw $\frac{3}{8}$ -16 x $1\frac{3}{4}$ Hex Hd.	2
14	00-478380-00003	Motor (Give Electrical Spec.)	1
15	00-478380-00001	Motor (Give Electrical Spec.)	1
16	00-478380-00005	Motor (Give Electrical Spec.)	1
17	00-478380-00007	Motor (Give Electrical Spec.)	1

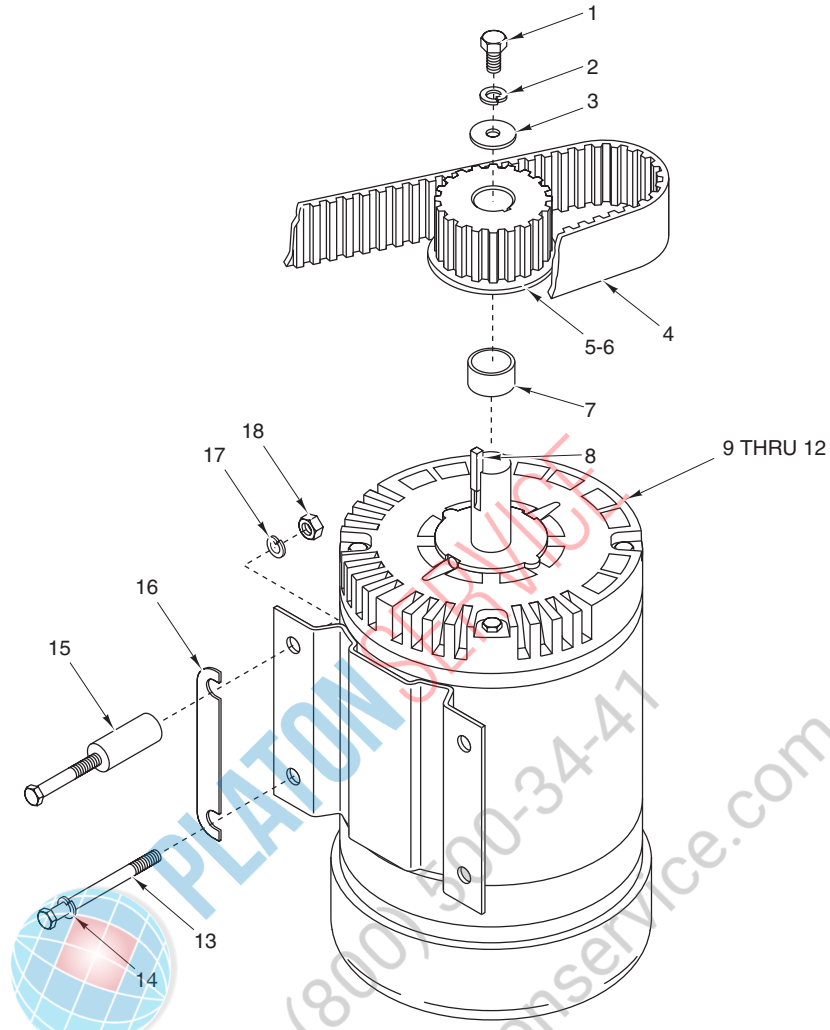

PL-55689

**MOTOR UNIT
(V1401 SERIES)**

ILLUS.	PART NO.	NAME OF PART	AMT.
	PL-55689		
1	SC-036-52	Cap Screw $\frac{3}{8}$ -16 x $\frac{3}{4}$ Hex Hd.	1
2	WL-004-06	Lockwasher $\frac{3}{8}$ Light	1
3	WS-018-41	Washer	1
4	00-068043	Flexa – Gear	1
5	00-478239	Pulley & Timing (20T) (60 Hz.)	1
6	00-478240	Pulley & Timing (23T) (50 Hz.)	1
7	00-118816	Spacer	1
8	00-109070	Key – $\frac{1}{4}$ x $\frac{1}{4}$ x $1\frac{1}{2}$	1
9	00-478380-00002	Motor Assy.	1
10	00-478380-00004	Motor (Give Electrical Spec.)	1
11	00-478380-00006	Motor (Give Electrical Spec.)	1
12	00-478380-00008	Motor (Give Electrical Spec.)	1
13	SC-062-09	Cap Screw $\frac{3}{8}$ -16 x 4 Hex Hd.	2
14	WL-004-06	Lockwasher $\frac{3}{8}$ Light	2
15	00-009007	Spacer – Motor	4
16	00-478323	Shim – Motor	AR
17	WL-004-06	Lockwasher $\frac{3}{8}$ Light	2
18	NS-013-22	Nut $\frac{3}{8}$ -16 Hex	2

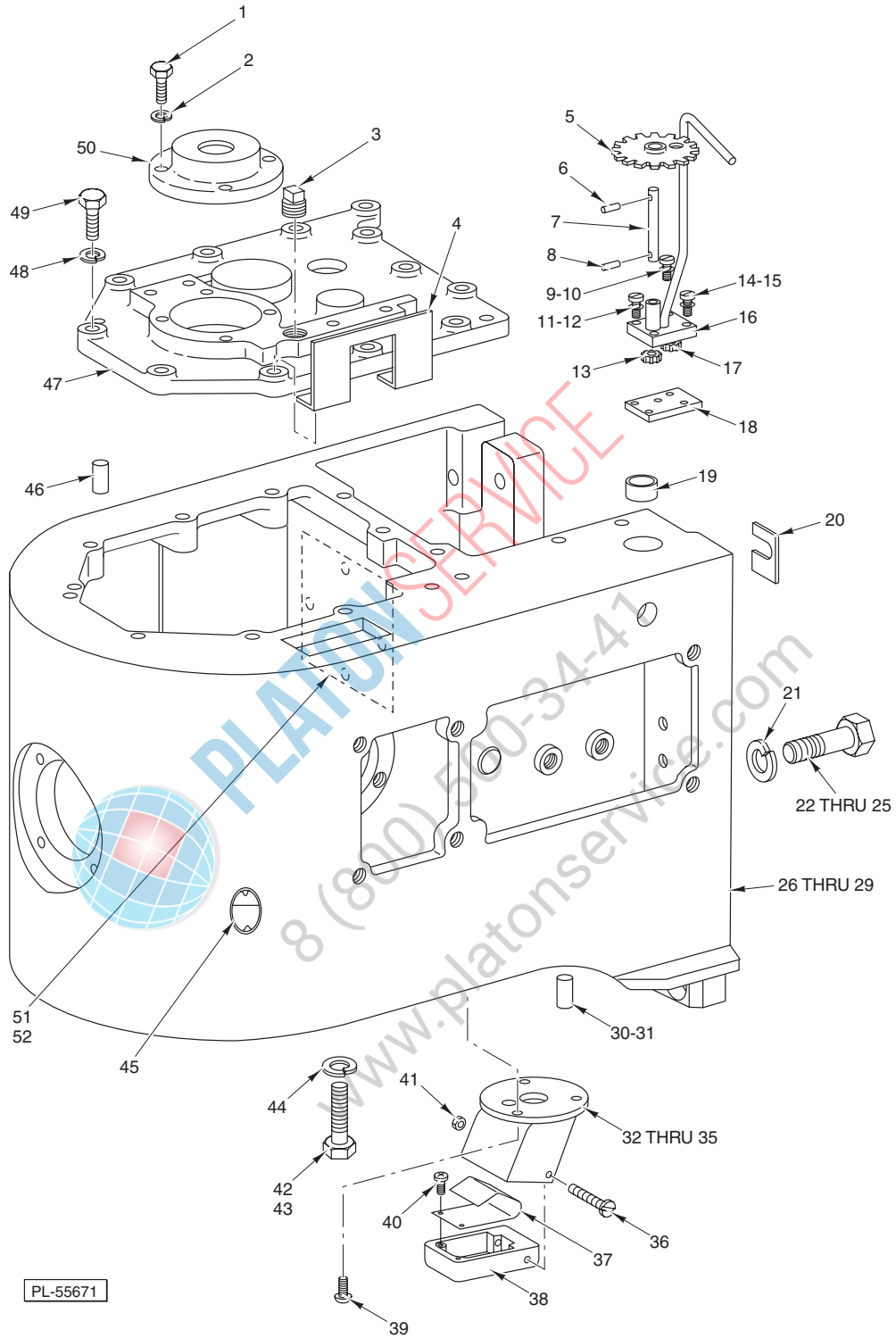

TRANSMISSION CASE UNIT

TRANSMISSION CASE UNIT

ILLUS. PL-55671	PART NO.	NAME OF PART	AMT.
1	SC-120-38	Cap Screw ⁵ / ₁₆ -18 x 1 Hex Hd.	4
2	WL-003-48	Lockwasher ⁵ / ₁₆ High Collar	4
3	FP-028-13	Pipe Plug ¹ / ₂ Sq. Hd.	1
4	00-479034	Stop – Clutch Arm	1
5	00-064554	Drive Gear Assy. (25T)	1
6	RP-002-08	Roll Pin ⁵ / ₆₄ Dia. x ¹¹ / ₁₆ Lg.	1
7	00-186272	Shaft – Oil Pump	1
8	00-538772	Dowel ³ / ₃₂ Dia. x ¹¹ / ₃₂ Lg.	1
9	SC-011-10	Mach. Screw 8-32 x ⁵ / ₈ Fil. Hd.	1
10	WL-003-15	Lockwasher #8 Light	1
11	SC-012-47	Mach. Screw 10-32 x ⁵ / ₈ Fil. Hd.	1
12	WL-003-22	Lockwasher #10 Light	1
13	00-186270	Gear – Oil Pump (15T) (Slotted)	1
14	SC-012-48	Mach. Screw 10-32 x ⁷ / ₈ Fil. Hd.	2
15	WL-003-22	Lockwasher #10 Light	2
16	00-123680	Housing & Tube Assy.	1
17	00-290277	Gear – Oil Pump (15T) (Slotted)	1
18	00-064488	Plate – Oil Pump Bottom	1
19	00-006651	Bushing – Insulating	3
20	00-072992-00003	Shim – Transmission Case (0.036 Thk.)	AR
21	WL-004-19	Lockwasher ⁵ / ₈ Medium	5
22	SC-037-98	Cap Screw ⁵ / ₈ -11 x 1 ³ / ₄ Hex Hd. (ML-104687, ML-104694, & ML-104696)	3
23	SC-037-93	Cap Screw ⁵ / ₈ -11 x 2 Hex Hd. (ML-104687, ML-104694, & ML-104696)	2
24	SC-062-16	Cap Screw ⁵ / ₈ -11 x 3 ³ / ₄ Hex Hd. (ML-104674, ML-104686, & ML-104683)	3
25	SC-062-17	Cap Screw ⁵ / ₈ -11 x 3 ¹ / ₂ Hex Hd. (ML-104674, ML-104686, & ML-104683)	2
26	00-074197-00009	Case – Transmission (Painted) (ML-104687, ML-104694, & ML-104696)	1
27	00-074197-00001	Case – Transmission (Deluxe) (ML-104687, ML-104694, & ML-104696)	1
28	00-074198-00004	Case – Transmission (Painted) (ML-104674, ML-104686, & ML-104683)	1
29	00-074198-00006	Case – Transmission (Deluxe) (ML-104674, ML-104686, & ML-104683)	1
30	00-011800-00180	Dowel (ML-104687, ML-104694, & ML-104696)	2
31	00-011800-00142	Dowel (ML-104674, ML-104686, & ML-104683)	2
32	00-438124-00002	Housing – Switch (Painted) (ML-104687, ML-104694, & ML-104696)	1
33	00-438124-00003	Housing – Switch (Deluxe) (ML-104687, ML-104694, & ML-104696)	1
34	00-438051-00002	Housing – Switch (Painted) (ML-104674, ML-104686, & ML-104683)	1
35	00-438051-00003	Housing – Switch (Deluxe) (ML-104674, ML-104686, & ML-104683)	1
36	SC-116-66	Mach. Screw 8-32 x 2 Rd. Hd.	1
37	00-437435	Spring – Reed Switch	1
38	00-087711-304-1	Housing – Reed Switch	1
39	SC-021-15	Mach. Screw 8-32 x ¹ / ₂ Rd Hd., Slotted	3
40	SC-018-50	Mach. Screw 6-32 x ¹ / ₄ Pan Hd.	2
41	NS-048-11	Lock Nut 8 x 32	1
42	SC-062-60	Cap Screw ¹ / ₂ -20 x 1 Hex Hd. (Painted)	1
43	SC-037-26	Cap Screw ¹ / ₂ -20 x 1 Hex Hd. (Deluxe)	1
44	WS-021-21	Washer	1
45	00-022793	Gauge – Oil Level	1
46	00-011800-00224	Dowel	2
47	00-106868	Cover – Transmission Case	1
48	WL-004-06	Lockwasher ³ / ₈ Light	11
49	SC-123-83	Cap Screw ³ / ₈ -16 x 1 ¹ / ₂ Hex Hd.	11
50	00-106867	Retainer – Upper Bearing	1
51	00-291641	Plate – Cover	1
52	SC-018-14	Mach. Screw 10-32 x ³ / ₈	4

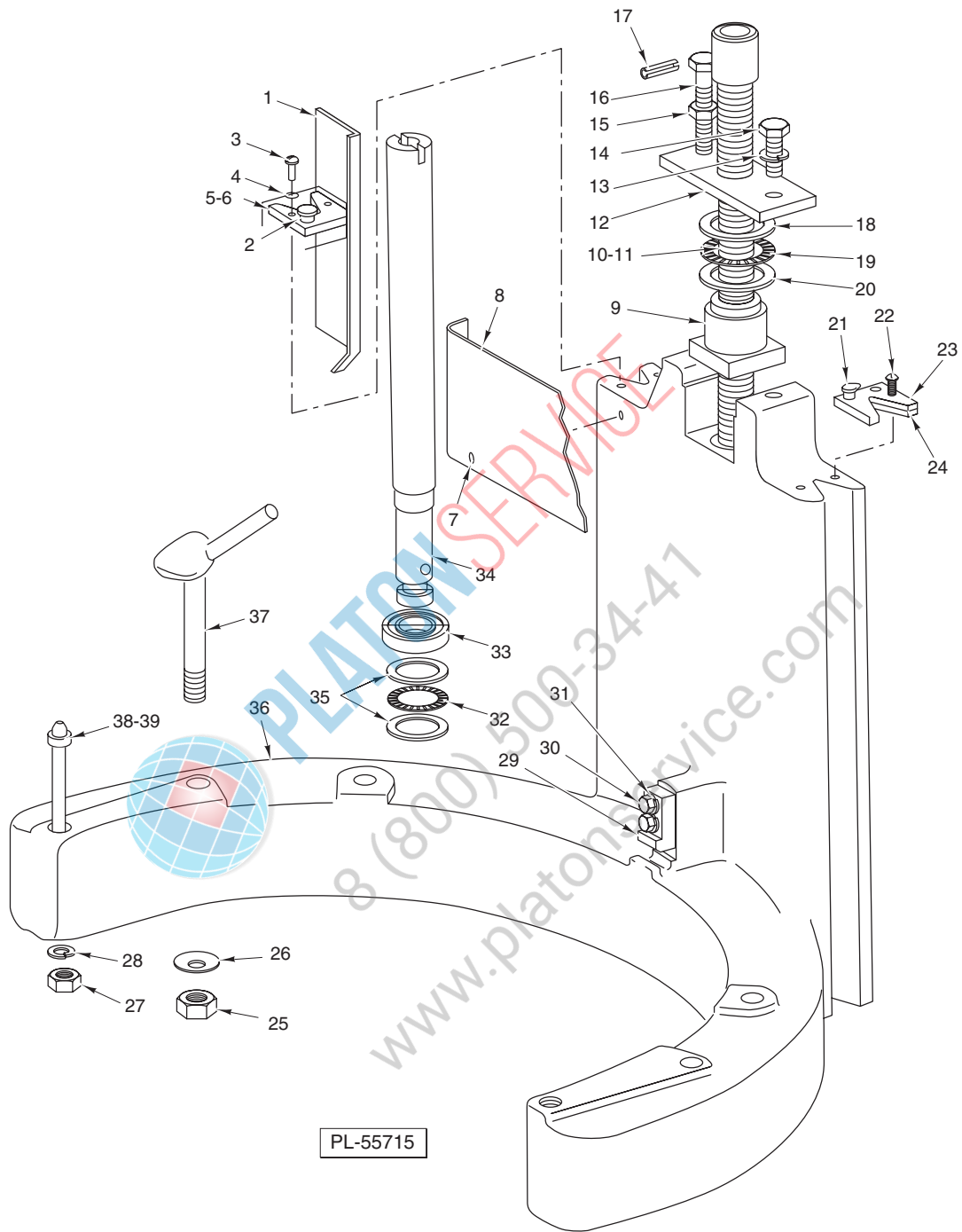

**BOWL SUPPORT UNIT
(M802 SERIES)**

**BOWL SUPPORT UNIT
(M802 SERIES)**

ILLUS. PL-55715	PART NO.	NAME OF PART	AMT.
1	00-439116	Bracket – Limit Switch	1
2	OG-003-23	Oiler	1
3	SC-112-39	Mach. Screw 8-32 x 3/4 Rd. Hd.	2
4	WL-007-07	Lockwasher #8 External Shakeproof	2
5	00-065682	Retainer – Wiper	1
6	00-065683	Wiper – Felt	1
7	SC-010-32	Mach. Screw 8-32 x 3/8 Truss Hd.	2
8	00-291195	Apron – Inner (Std.)	1
9	00-068322	Nut – Bowl Lift	1
10	00-290367-00001	Screw – Bowl Lift (Std.)	1
11	00-290367-00002	Screw Bowl Lift (ML-104694 & ML-104686)	1
12	00-064392	Retainer – Nut	1
13	WL-004-13	Lockwasher 1/2 Medium	1
14	SC-036-98	Cap Screw 1/2-13 x 1 1/4 Hex Hd.	1
15	NS-013-30	Nut 1/2-13 Hex	1
16	SC-124-95	Stop Screw – Bowl Yoke (Cap Screw 1/2-13 x 3 1/2 Hex Hd.)	1
17	PS-004-21	Spiral Pin 3/8 Dia. 1/2 Lg.	1
18	00-068321	Washer – Lift Screw Thrust	1
19	BN-002-11	Needle Bearing – Thrust	1
20	00-068321	Washer – Lift Screw Thrust	1
21	OG-003-23	Oiler	1
22	SC-011-10	Mach. Screw 8-32 x 5/8 Rd. Hd.	2
23	00-065682	Retainer – Wiper	1
24	00-065683	Wiper – Felt	1
25	NS-046-18	Lock Nut 5/8-11 Hex (Nylok)	2
26	00-064636	Washer – Bowl Clamp	2
27	NS-013-30	Nut 1/2-13 Hex	2
28	WL-004-11	Lockwasher 1/2 Light	2
29	00-064394	Retainer – Bowl	1
30	SC-036-27	Cap Screw 5/16-18 x 1 Hex Hd.	2
31	WL-003-44	Lockwasher 5/16 Medium	2
32	BN-002-18	Needle Bearing – Torrington (#NTA-1423)	1
33	BB-015-08	Ball Bearing (MRC 105KSZZ-01-ST-A-92-C)	1
34	00-064389	Extension – Lift Screw	1
35	00-064558	Washer – Trust	2
36	00-122929-00002	Support Bowl	1
37	00-065922-00020	Bowl Clamp Assy.	2
38	WS-008-02	Washer	AR
39	00-020979-00001	Stud – Bowl Locating	2

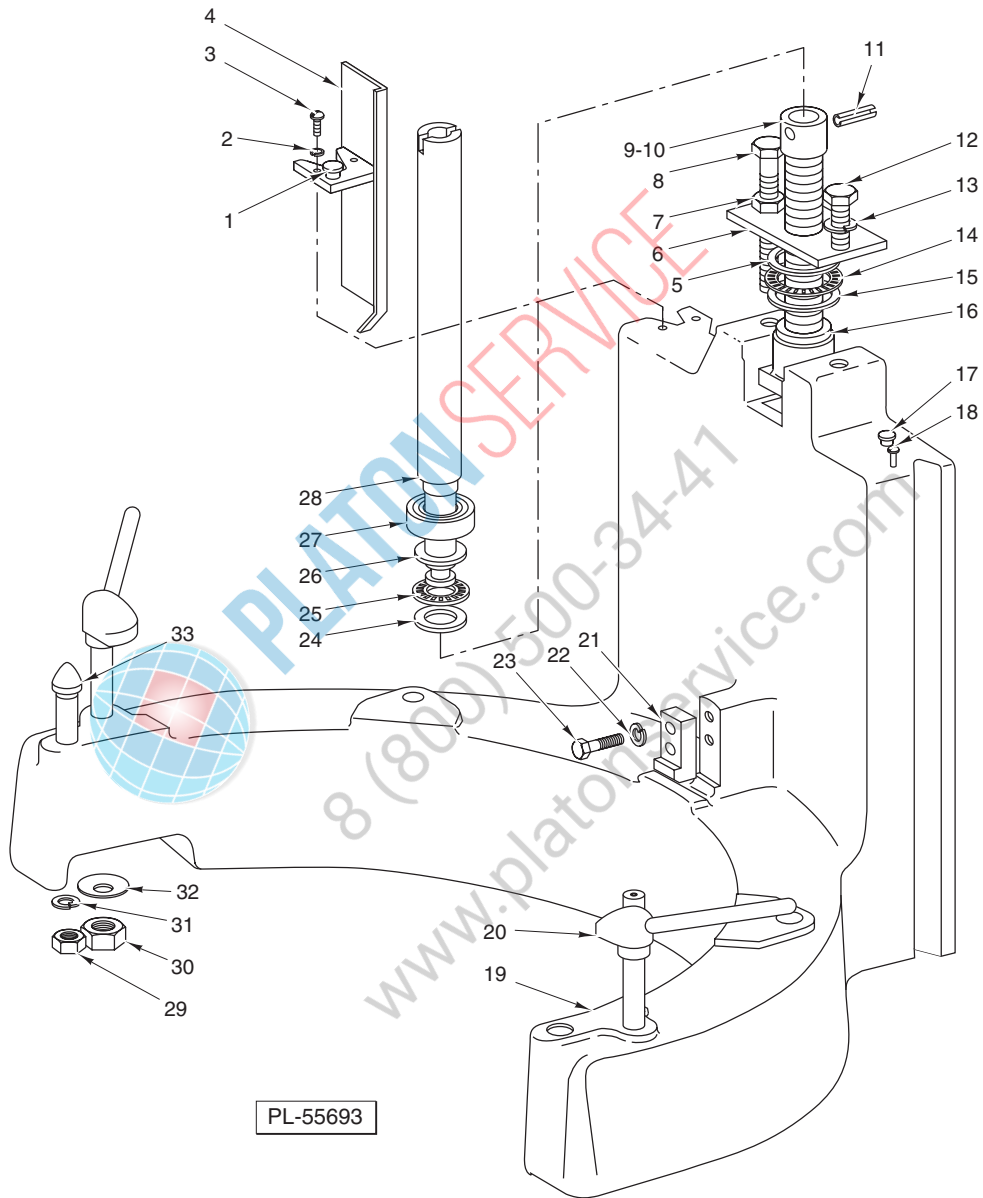

**BOWL SUPPORT UNIT
(V1401 SERIES)**

**BOWL SUPPORT UNIT
(V1401 SERIES)**

ILLUS. PL-55693	PART NO.	NAME OF PART	AMT.
1	OG-003-23	Oiler	1
2	WL-007-07	Lockwasher #8 External	2
3	SC-009-68	Mach. Screw 8-32 x 3/4 Rd. Hd.	2
4	00-439117	Bracket – Limit Switch	1
5	00-068321	Washer – Lift Screw Thrust	1
6	00-067955	Retainer – Nut	1
7	NS-013-30	Nut 1/2-13 Hex	1
8	SC-124-93	Stop Screw – Bowl Yoke	1
9	00-290367-00004	Bowl Lift Screw Assy. (ML-104686)	1
10	00-290367-00003	Bowl Lift Screw Assy. (ML-104674 & ML-104683)	1
11	PS-004-21	Spiral Pin 3/8 Dia. x 1 1/2 Lg.	1
12	SC-036-98	Cap Screw 1/2-13 x 1 1/4 Hex Hd.	1
13	WL-004-13	Lockwasher 1/2 Medium	1
14	BN-002-11	Needle Bearing – Thrust	1
15	00-068321	Washer – Lift Screw Thrust	1
16	00-068322	Nut – Bowl Lift	1
17	OG-003-23	Oiler	2
18	SC-007-44	Mach. Screw 8-32 x 5/8 Rd. Hd.	2
19	00-122930-00002	Support Bowl	1
20	00-065922-00020	Bowl Clamp Assy.	2
21	00-064394	Retainer – Bowl	1
22	WL-003-44	Lockwasher 5/16 Medium	2
23	SC-120-38	Cap Screw 5/16-18 x 1 Hex Hd.	2
24	00-064558	Washer – Thrust	1
25	BN-002-18	Needle Bearing – Torrington (#NTA-1423)	1
26	00-064558	Washer – Trust	1
27	BB-017-39	Ball Bearing (MRC 205 SZZ-01-ST-A-92-C)	1
28	00-064389	Extension – Lift Screw	1
29	NS-013-30	Nut 1/2-13 Hex	2
30	NS-046-18	Lock Nut 5/8-11 Hex Nylok	2
31	WL-004-11	Lockwasher 1/2 Light	2
32	00-064636	Washer – Bowl Clamp	2
33	00-019195-00001	Stud – Bowl Locating	2

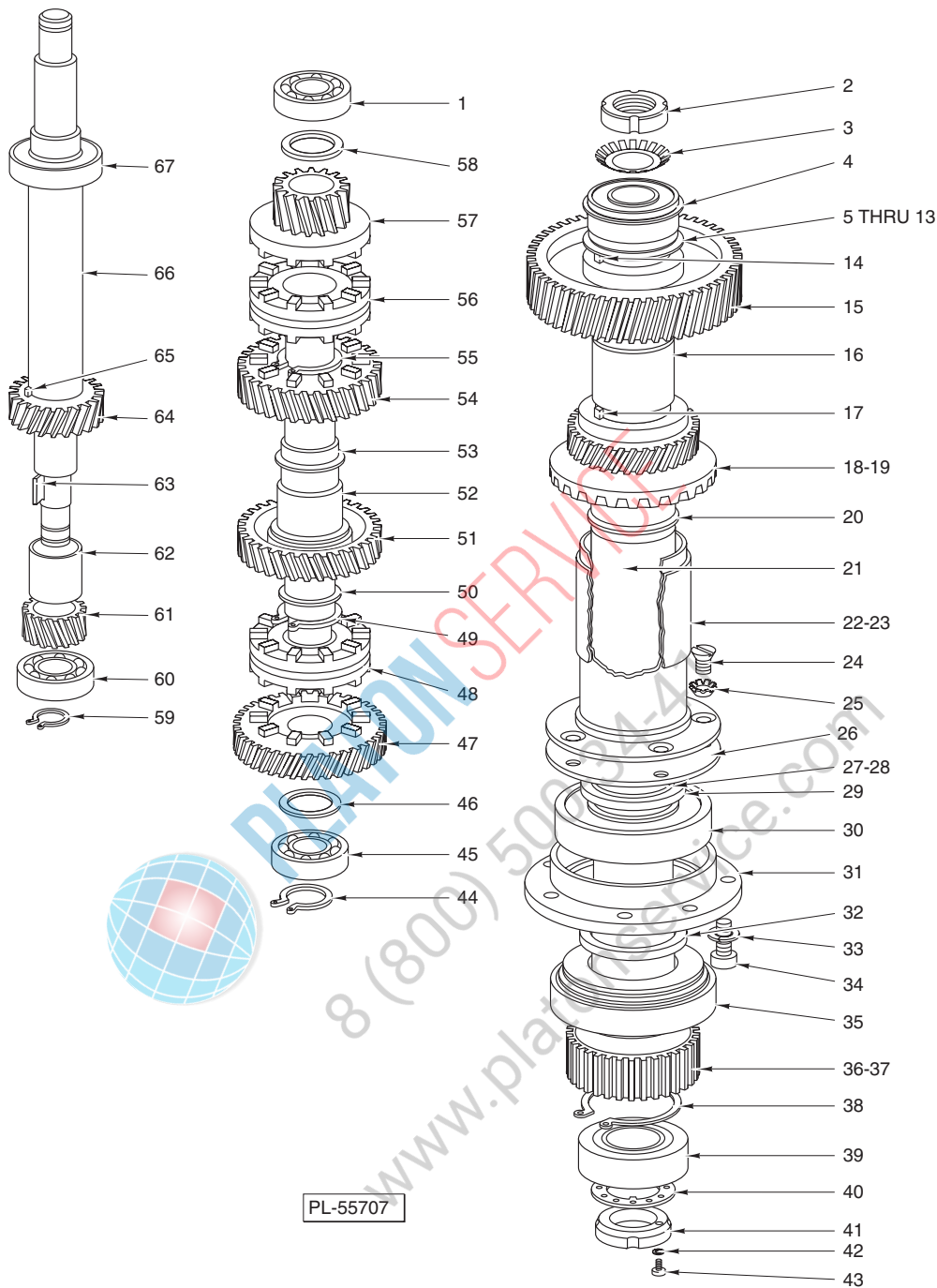

**TRANSMISSION GEAR UNIT
(M802 SERIES)**

ILLUS.	PART NO.	NAME OF PART	AMT.
PL-55707			
1	BB-018-33	Ball Bearing (Fafnir #205KF)	1
2	NS-034-08	Lock Nut – N.D. #N-07	1
3	WL-017-09	Lockwasher – TW107	1
4	BB-009-13	Ball Bearing (MRC-5207KFFG)	1
5	00-106888-00001	Shim – Planetary Shaft (0.141 Thk.)	AR
6	00-106888-00002	Shim – Planetary Shaft (0.144 Thk.)	AR

**TRANSMISSION GEAR UNIT (Cont.)
(M802 SERIES)**

ILLUS. PL-55707	PART NO.	NAME OF PART	AMT.
7	00-106888-00003	Shim – Planetary Shaft (0.147 Thk.)	AR
8	00-106888-00004	Shim – Planetary Shaft (0.150 Thk.)	AR
9	00-106888-00005	Shim – Planetary Shaft (0.153 Thk.)	AR
10	00-106888-00006	Shim – Planetary Shaft (0.156 Thk.)	AR
11	00-106888-00007	Shim – Planetary Shaft (0.159 Thk.)	AR
12	00-106888-00009	Shim – Planetary Shaft (0.165 Thk.)	AR
13	00-106888-00011	Shim – Planetary Shaft (0.171 Thk.)	AR
14	00-012430-00215	Key	1
15	00-024225	Gear – Upper Planetary Shaft (53T)	1
16	00-064710	Spacer – Planetary Shaft	1
17	00-012430-00211	Key	1
18	00-064421-00002	Gear – Cluster (33T) & (25T Bevel) (Use with Attachment Hub)	1
19	00-291603-00002	Gear (33T) (Use W/O Attachment Hub)	1
20	00-067500-00022	O-Ring	1
21	00-106889	Shaft – Planetary	1
22	00-064427	Chimney & Flange Assy. (Prior to 31-1241-981)	1
23	00-874373	Chimney	1
24	SC-014-75	Mach. Screw 1/4-20 x 7/16 Flat Hd. (Prior to 31-1241-981)	5
25	WL-009-08	Lockwasher 1/4 External Shakeproof (Prior to 31-1241-981)	5
26	00-064623	Gauge – Gasket for Chimney (Prior to 31-1241-981)	1
27	00-067500-00102	O-Ring (Prior to 31-1241-981)	1
28	00-067500-00142	O-Ring	1
29	00-064467	Spacer – Lower Bearing Upper	1
30	BB-007-07	Ball Bearing (MRC #211 S-ZZ)	1
31	00-064423	Carrier – Lower Bearing	1
32	00-064468	Space – Lower Bearing Lower	1
33	WL-003-48	Lockwasher 5/16 High Collar	6
34	SC-123-75	Cap Screw 5/16-18 x 3/4 Soc. Fil. Hd.	6
35	BR-002-14	Roller Bearing – Cup & Cone Assy.	1
36	00-064386	Sun Gear (23T)	1
37	00-012430-00210	Key 5/16 x 5/16 x 1 5/8	1
38	RR-004-14	Retaining Ring	1
39	BR-002-15	Roller Bearing – Cup & Cone Assy.	1
40	00-064982	Washer – Tongue	1
41	00-065275	Lock Nut – (Special) Bearing	1
42	WL-003-15	Lockwasher #8 Light	1
43	00-065277	Cap Screw – (Special)	1
44	RR-005-04	Retaining Ring (Spirolox)	1
45	BB-018-21	Ball Bearing (Fafnir #305KD)	1
46	00-074222	Spacer – Clutch Shaft (Lower)	1
47	00-024539	Lower Clutch & Lower Gear Assy. (49T)	1
48	00-024213	Clutch – Shifting	1
49	RR-005-14	Retaining Ring	1
50	00-060767	Washer – Clutch Shaft	1
51	00-024538	Lower Clutch & Upper Gear Assy. (41T)	1
52	00-024209	Shaft – Clutch	1
53	00-024216	Washer – Clutch Shaft	1
54	00-064698	Upper Clutch Lower Gear Assy. (35T)	1
55	RR-004-13	Retaining Ring	1
56	00-024213	Clutch – Shifting	1
57	00-024545	Upper Clutch & Upper Gear Assy. (17T)	1
58	00-024210	Spacer – Clutch Shaft	1
59	RR-004-07	Retaining Ring	1
60	BB-006-01	Ball Bearing (N.D. #3304)	1
61	00-121382	Gear – Lower Worm Shaft (17T)	1
62	00-024206	Spacer – Worm Gear Shaft	1
63	00-120937	Key – (Special)	1
64	00-024207	Gear – Upper Worm Shaft (25T)	1
65	00-064670	Key – (Special)	1
66	00-074221	Shaft – Main Drive	1
67	BB-007-46	Ball Bearing (N.D. #7506)	1

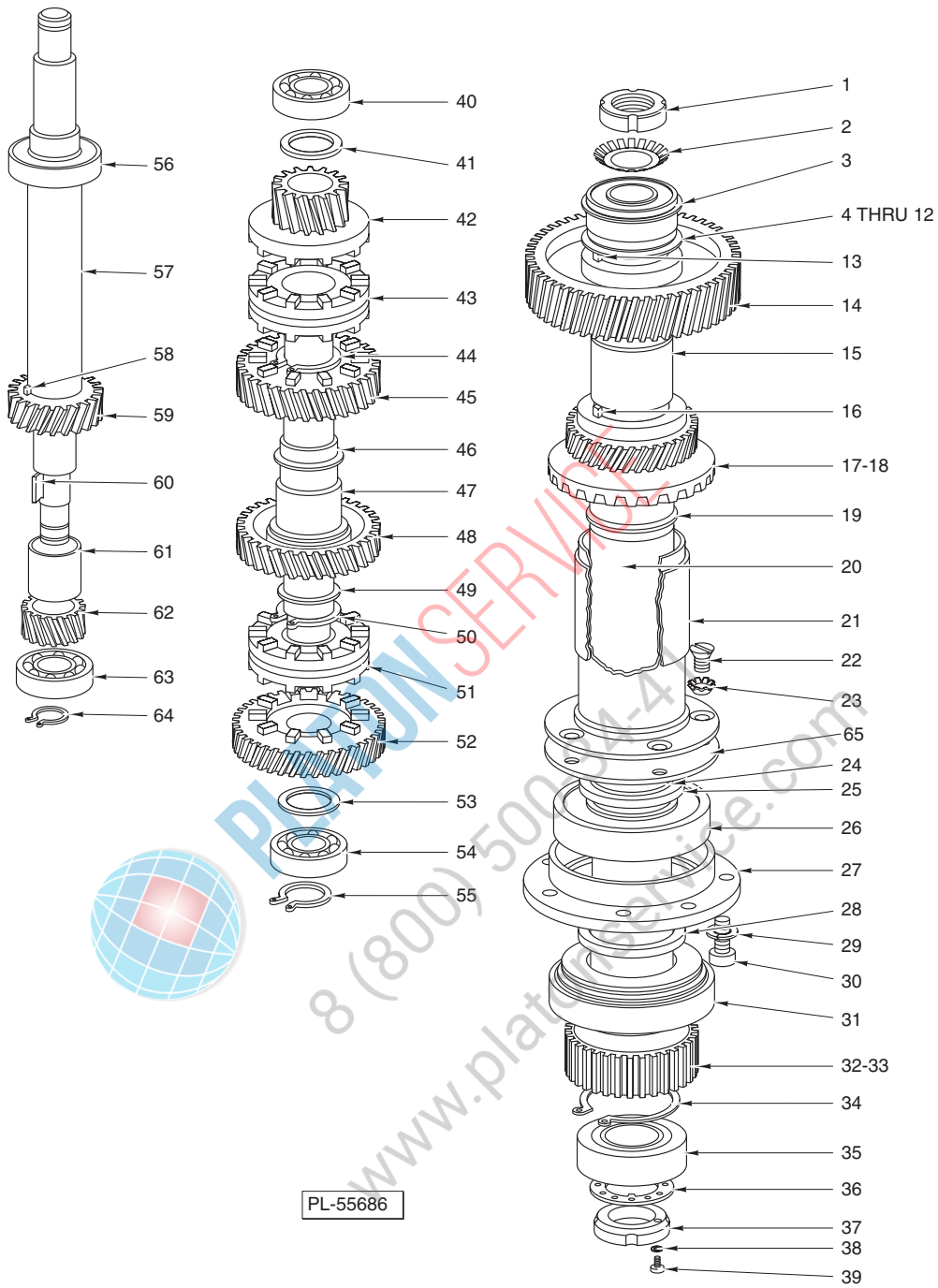

**TRANSMISSION GEAR UNIT
(V1401 SERIES)**

ILLUS.	PART NO.	NAME OF PART	AMT.
PL-55686			
1	NS-034-08	Lock Nut – N.D. #N-07	1
2	WL-017-09	Lockwasher – TW107	1
3	BB-009-13	Ball Bearing (MRC-5207KFFG)	1
4	00-106888-00001	Shim – Planetary Shaft (0.141 Thk.)	AR
5	00-106888-00002	Shim – Planetary Shaft (0.144 Thk.)	AR
6	00-106888-00003	Shim – Planetary Shaft (0.147 Thk.)	AR

**TRANSMISSION GEAR UNIT (Cont.)
(V1401 SERIES)**

ILLUS.	PART NO.	NAME OF PART	AMT.
PL-55686			
7	00-106888-00004	Shim – Planetary Shaft (0.150 Thk.)	AR
8	00-106888-00005	Shim – Planetary Shaft (0.153 Thk.)	AR
9	00-106888-00006	Shim – Planetary Shaft (0.156 Thk.)	AR
10	00-106888-00007	Shim – Planetary Shaft (0.159 Thk.)	AR
11	00-106888-00009	Shim – Planetary Shaft (0.165 Thk.)	AR
12	00-106888-00011	Shim – Planetary Shaft (0.171 Thk.)	AR
13	00-012430-00215	Key	1
14	00-024225	Gear – Upper Planetary Shaft (53T)	1
15	00-067891	Spacer – Planetary Shaft	1
16	00-012430-00209	Key	1
17	00-067894-00002	Gear – Cluster (33T) & (25T) (Use with Attachment Hub)	1
18	00-291607-00002	Gear (33T) (Use W/O Attachment Hub)	1
19	00-067500-00118	O-Ring	1
20	00-106890	Shaft – Planetary	1
21	00-067897	Chimney & Flange Assy.	1
22	SC-014-75	Mach. Screw 1/4-20 x 7/16 Flat Hd.	5
23	WL-009-08	Lockwasher 1/4 External Shakeproof	5
24	00-067500-00102	O-Ring	1
25	00-067900	Spacer – Lower Bearing Upper	1
26	BB-008-32	Ball Bearing (MRC #212-MFZ)	1
27	00-067896	Carrier – Lower Bearing	1
28	00-067901	Spacer – Lower Bearing Lower	1
29	WL-003-48	Lockwasher 5/16 High Collar	6
30	SC-123-75	Cap Screw 5/16-18 x 3/4 Soc. Fil. Hd.	6
31	BR-002-31	Roller Bearing – Cup & Cone Assy.	1
32	00-067804	Sun Gear (23T)	1
33	00-12430-00161	Key – Sun Gear	1
34	RR-011-96	Retaining Ring	1
35	BR-002-15	Roller Bearing – Cup & Cone Assy.	1
36	00-064982	Washer – Tongue	1
37	00-065275	Lock Nut – (Special) Bearing	1
38	WL-003-15	Lockwasher #8 Light	1
39	00-065277	Cap Screw – (Special)	1
40	BB-008-30	Ball Bearing (Fafnir #205W)	1
41	00-024210	Spacer – Clutch Shaft	1
42	00-024545	Upper Clutch & Upper Gear Assy. (17T)	1
43	00-024213	Clutch – Shifting	1
44	RR-004-13	Retaining Ring (Truarc)	1
45	00-064698	Upper Clutch Lower Gear Assy. (35T)	1
46	00-024216	Washer – Clutch Shaft	1
47	00-024209	Shaft – Clutch	1
48	00-024538	Lower Clutch & Upper Gear Assy. (41T)	1
49	00-060767	Washer – Clutch Shaft	1
50	RR-005-14	Retaining Ring	1
51	00-024213	Clutch – Shifting	1
52	00-024539	Lower Clutch & Lower Gear Assy. (49T)	1
53	00-074222	Spacer – Clutch Shaft (Lower)	1
54	BB-018-22	Ball Bearing (Fafnir #7305W)	1
55	RR-005-04	Retaining Ring (Spirolox)	1
56	BB-007-46	Ball Bearing (N.D. #7506)	1
57	00-074221	Shaft – Main Drive	1
58	00-064670	Key – (Special)	1
59	00-024207	Gear – Upper Worm Shaft (25T)	1
60	00-120937	Key – (Special)	1
61	00-024206	Spacer – Worm Gear Shaft	1
62	00-121382	Gear – Lower Worm Shaft (17T)	1
63	BB-010-16	Ball Bearing (NTN #5304)	1
64	RR-004-07	Retaining Ring	1
65	00-068227	Gauge – Gasket Chimney	1

MODELS M802 & V1401 SERIES MIXERS REPLACEMENT PARTS

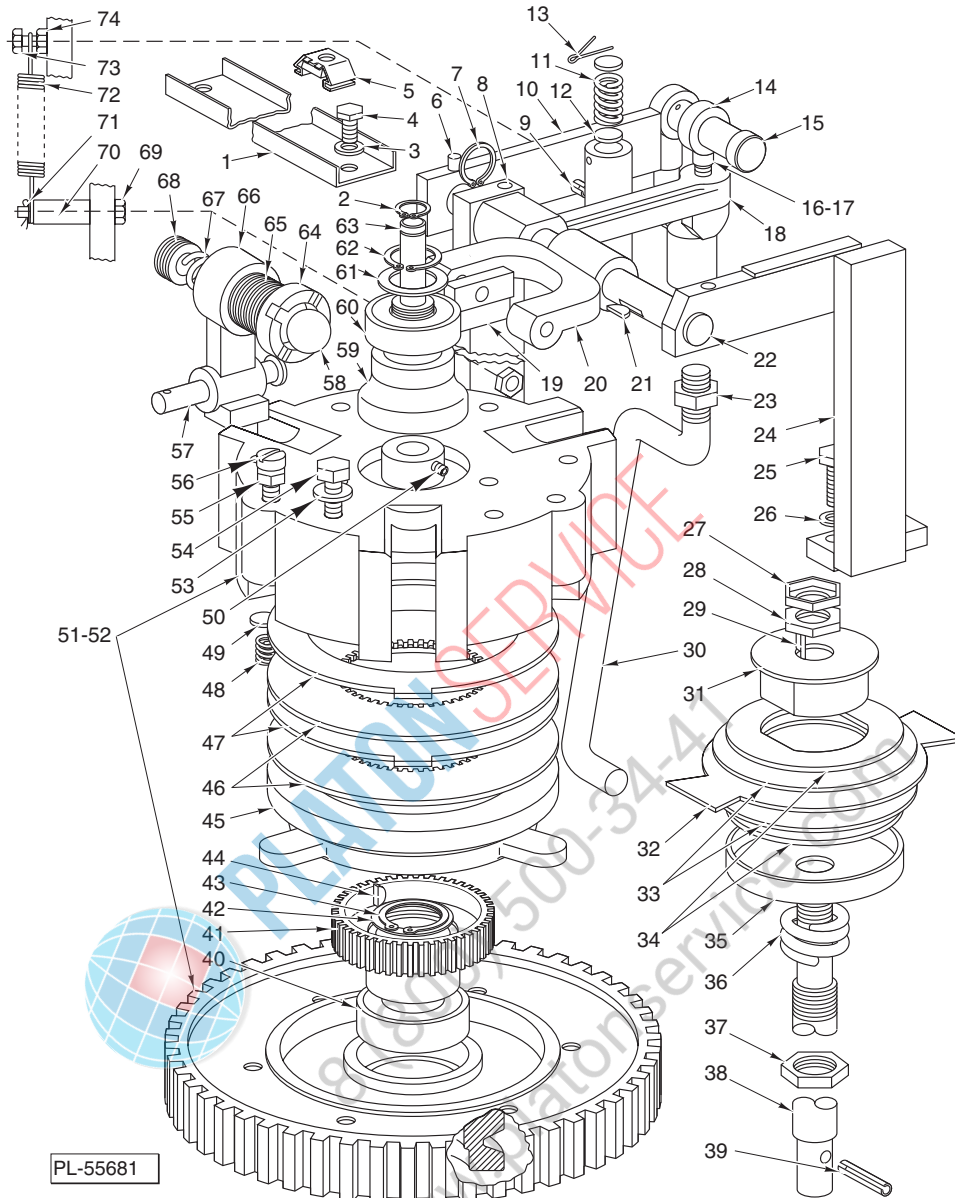

PL-55681

**CLUTCH AND BRAKE UNIT
(M802 SERIES)**

ILLUS.	PART NO.	NAME OF PART	AMT.
PL-55681			
1	00-064528	Channel – Top Anchoring	1
2	RR-004-17	Retaining Ring	1
3	WL-003-36	Lockwasher 1/4 Light	2
4	SC-062-20	Cap Screw 1/4-20 x 3/8 Hex Hd.	2
5	00-064652	Nut – (Special)	1
6	PS-004-15	Spiral Pin 1/4 Dia. x 1 1/8 Lg.	1
7	RR-004-18	Retaining Ring	2
8	00-064526	Clutch Shaft Support Assy. (RH)	1
9	PS-004-15	Spiral Pin 1/4 Dia. x 1 1/8 Lg.	1
10	00-103654	Bracket and Clutch Arm Assy. (Incls. Item 9)	1
11	00-007433-00001	Spring – Brake Arm	1
12	00-011352	Disc – Spring	2
13	PC-003-38	Cotter Pin 3/32 x 1 1/4	1
14	00-479027	Clevis – Clutch Rod	1

**CLUTCH AND BRAKE UNIT (Cont.)
(M802 SERIES)**

ILLUS. PL-55681	PART NO.	NAME OF PART	AMT.
15	00-479032	Pin – Clevis	1
16	SC-040-22	Cap Screw 3/8-16 x 1 Soc. Hd.	1
17	NS-013-22	Nut 3/8-16 Hex	1
18	00-068529	Brake Arm Assy. (Incls. Items 16 & 17)	1
19	00-103655	Clutch Bearing Retainer Assy.	2
20	00-064532	Yoke – Clutch Shifting	1
21	00-012430-00048	Key 3/16 Sq. x 3/4 Lg.	1
22	00-439316	Shaft – Clutch	1
23	NS-013-35	Nut 1/2-20 Hex	1
24	00-064527	Clutch Shaft Support Assy. (LH)	1
25	SC-120-38	Cap Screw 5/16-18 x 1 Hex Hd.	4
26	WL-003-44	Lockwasher 5/16 Medium	4
27	NS-035-21	Special Nut 5/8-18 Palnut	1
28	NS-017-40	Jam Nut 5/8-18 Hex	1
29	00-012430-00024	Key	1
30	00-479025	Rod – Clutch	1
31	00-064479	Hub – Brake	1
32	00-064482	Plate – Engaging	1
33	00-064480	Washer – Friction	2
34	00-022489	Disc – Friction	2
35	00-064481	Plate – Pressure	1
36	00-010107	Spring – Brake	1
37	NS-017-49	Jam Nut 3/4-16 Hex	1
38	00-064483	Shaft – Brake	1
39	RP-002-27	Roll Pin 5/16 x 1 Lg.	1
40	BB-015-08	Ball Bearing (MRC 105KSZZ-01-ST-A-92-C)	3
41	00-064434	Hub – Spline	1
42	WS-013-44	Washer – Shim	2
43	RR-004-09	Retaining Ring	1
44	00-064670	Key (Special)	1
45	00-064429-00001	Plate – Pressure	1
46	00-873117	Disc – Inner	2
47	00-064432	Disc – Outer	2
48	00-018046	Spring – Release	3
49	00-011352	Disc – Spring	3
50	SC-064-03	Set Screw 1/4-28 x 1/4 Soc. Hdls., Cup Pt. Nylc	1
51	00-110702	Driven Gear (54T) & Clutch Arm Plate (60 Hz.) (Incls. Items 53 & 54)	1
52	00-110700	Driven Gear (51T) & Clutch Arm Plate (50 Hz.) (Incls. Items 53 & 54)	1
53	WL-003-44	Lockwasher 5/16 Medium	6
54	SC-037-96	Cap Screw 5/16-18 x 2 3/4 Hex Hd.	6
55	NS-017-08	Jam Nut 5/16-18 Hex	3
56	SC-012-02	Mach. Screw 5/16-18 x 1 1/2 Fil. Hd.	3
57	00-478789	Pin – Clutch Arm Pivot	3
58	BA-002-23	Ball 1/2 Dia.	3
59	00-064529	Cam – Clutch Operating	1
60	BB-015-03	Ball Bearing (N.D. #773LO4)	1
61	WS-012-41	Washer	1
62	RR-004-07	Retaining Ring	1
63	00-072558	Post – Guide	1
64	00-007344	Lock Nut	3
65	00-103652	Clutch Spring Screw Assy. (Incls. Items 58, 64, 66, 67, & 68)	3
66	00-064430	Arm – Clutch	3
67	00-008827	Spring – Ball Operating	3
68	00-007343	Screw – Hollow	3
69	NS-017-06	Jam Nut 5/16-18 Hex	1
70	00-065122	Stud – Spring Mounting	1
71	WS-003-20	Washer	1
72	00-065084-00003	Spring – Clutch Linkage	1
73	SC-036-04	Cap Screw 1/4-20 x 3/4 Hex Hd.	1
74	NS-013-01	Nut 1/4-20 Hex	1
	00-110708-00001	Clutch Assy.	1
	00-103653	Clutch Control Assy.	1
	00-103650	Brake Shaft Assy.	1

MODELS M802 & V1401 SERIES MIXERS REPLACEMENT PARTS

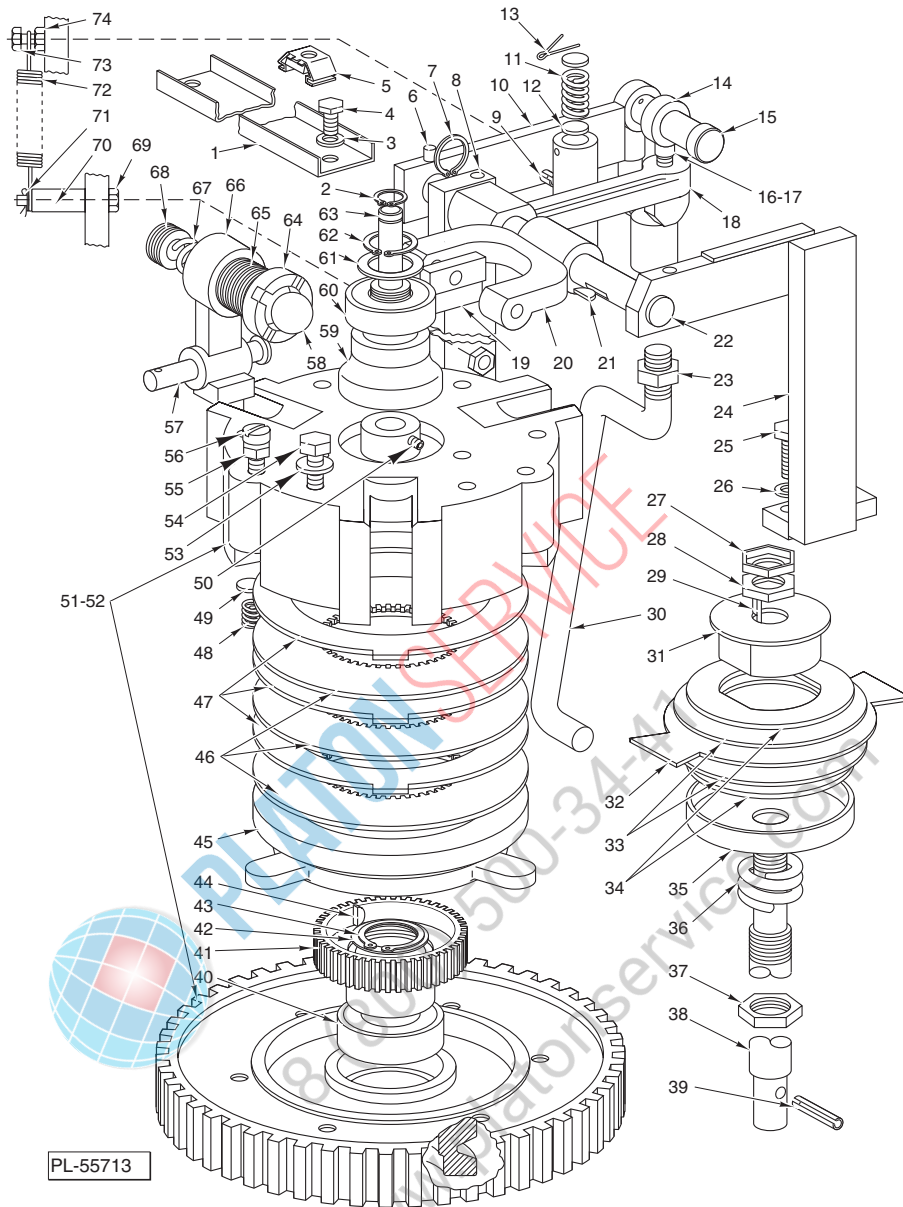

PL-55713

**CLUTCH AND BRAKE UNIT
(V1401 SERIES)**

ILLUS.	PART NO.	NAME OF PART	AMT.
PL-55713			
1	00-064528	Channel – Top Anchoring	1
2	RR-004-17	Retaining Ring	1
3	WL-003-36	Lockwasher 1/4 Light	2
4	SC-062-20	Cap Screw 1/4-20 x 3/8 Hex Hd.	2
5	00-064652	Nut – (Special)	1
6	PS-004-15	Spiral Pin 1/4 Dia. x 1 1/8 Lg.	1
7	RR-004-18	Retaining Ring	2
8	00-064526	Clutch Shaft Support Assy. (RH)	1
9	PS-004-15	Spiral Pin 1/4 Dia. x 1 1/8 Lg.	1
10	00-103654	Bracket and Clutch Arm Assy. (Incls. Item 9)	1
11	00-007433-00001	Spring – Brake Arm	1
12	00-011352	Disc – Spring	2
13	PC-003-38	Cotter Pin 3/32 x 1 1/4	1
14	00-479027	Clevis – Clutch Rod	1

**CLUTCH AND BRAKE UNIT (Cont.)
(V1401 SERIES)**

ILLUS. PL-55713	PART NO.	NAME OF PART	AMT.
15	00-479032	Pin – Clevis	1
16	SC-040-22	Cap Screw ³ / ₈ -16 x 1 Soc. Hd.	1
17	NS-013-22	Nut ³ / ₈ -16 Hex	1
18	00-068529	Brake Arm Assy. (Incls. Items 16 & 17)	1
19	00-103655	Clutch Bearing Retainer Assy.	2
20	00-064532	Yoke – Clutch Shifting	1
21	00-012430-00048	Key ³ / ₁₆ Sq. x ³ / ₄ Lg.	1
22	00-439316	Shaft – Clutch	1
23	NS-013-35	Nut ¹ / ₂ -20 Hex	1
24	00-064527	Clutch Shaft Support Assy. (LH)	1
25	SC-120-38	Cap Screw ⁵ / ₁₆ -18 x 1 Hex Hd.	4
26	WL-003-44	Lockwasher ⁵ / ₁₆ Medium	4
27	NS-035-21	Special Nut ⁵ / ₈ -18 Palnut	1
28	NS-017-40	Jam Nut ⁵ / ₈ -18 Hex	1
29	00-012430-00024	Key	1
30	00-479025	Rod – Clutch	1
31	00-064479	Hub – Brake	1
32	00-064482	Plate – Engaging	1
33	00-064480	Washer – Friction	2
34	00-022489	Disc – Friction	2
35	00-064481	Plate – Pressure	1
36	00-010107	Spring – Brake	1
37	NS-017-49	Jam Nut ³ / ₄ -16 Hex	1
38	00-064483	Shaft – Brake	1
39	RP-002-27	Roll Pin ⁵ / ₁₆ x 1 Lg.	1
40	BB-015-08	Ball Bearing (MRC 105KSZZ-01-ST-A-92-C)	3
41	00-064434	Hub – Spline	1
42	WS-013-44	Washer – Shim	2
43	RR-004-09	Retaining Ring	1
44	00-064670	Key (Special)	1
45	00-064429-00002	Plate – Pressure	1
46	00-873117	Disc – Inner	2
47	00-064432	Disc – Outer	2
48	00-018046	Spring – Release	3
49	00-011352	Disc – Spring	3
50	SC-064-03	Set Screw ¹ / ₄ -28 x ¹ / ₄ Soc. Hdls., Cup Pt. Nyloc	1
51	00-110706	Driven Gear (54T) & Clutch Arm Plate (60 Hz.) (Incls. Items 53 & 54)	1
52	00-110704	Driven Gear (51T) & Clutch Arm Plate (50 Hz.) (Incls. Items 53 & 54)	1
53	WL-003-44	Lockwasher ⁵ / ₁₆ Medium	6
54	SC-037-96	Cap Screw ⁵ / ₁₆ -18 x 2 ³ / ₄ Hex Hd.	6
55	NS-017-08	Jam Nut ⁵ / ₁₆ -18 Hex	3
56	SC-012-02	Mach. Screw ⁵ / ₁₆ -18 x 1 ¹ / ₂ Fil. Hd.	3
57	00-478789	Pin – Clutch Arm Pivot	3
58	BA-002-23	Ball ¹ / ₂ Dia.	3
59	00-064529	Cam – Clutch Operating	1
60	BB-015-03	Ball Bearing (N.D. #773LO4)	1
61	WS-012-41	Washer	1
62	RR-004-07	Retaining Ring	1
63	00-072558	Post – Guide	1
64	00-007344	Lock Nut	3
65	00-103652	Clutch Spring Screw Assy. (Incls. Items 58, 64, 66, 67, & 68)	3
66	00-064430	Arm – Clutch	3
67	00-008827	Spring – Ball Operating	3
68	00-007343	Screw – Hollow	3
69	NS-017-06	Jam Nut ⁵ / ₁₆ -18 Hex	1
70	00-065122	Stud – Spring Mounting	1
71	WS-003-20	Washer	1
72	00-065084-00003	Spring – Clutch Linkage	1
73	SC-036-04	Cap Screw ¹ / ₄ -20 x ³ / ₄ Hex Hd.	1
74	NS-013-01	Nut ¹ / ₄ -20 Hex	1
	00-110708-00003	Clutch Assy.	1
	00-103653	Clutch Control Assy.	1
	00-103650	Brake Shift Assy.	1

MODELS M802 & V1401 SERIES MIXERS REPLACEMENT PARTS

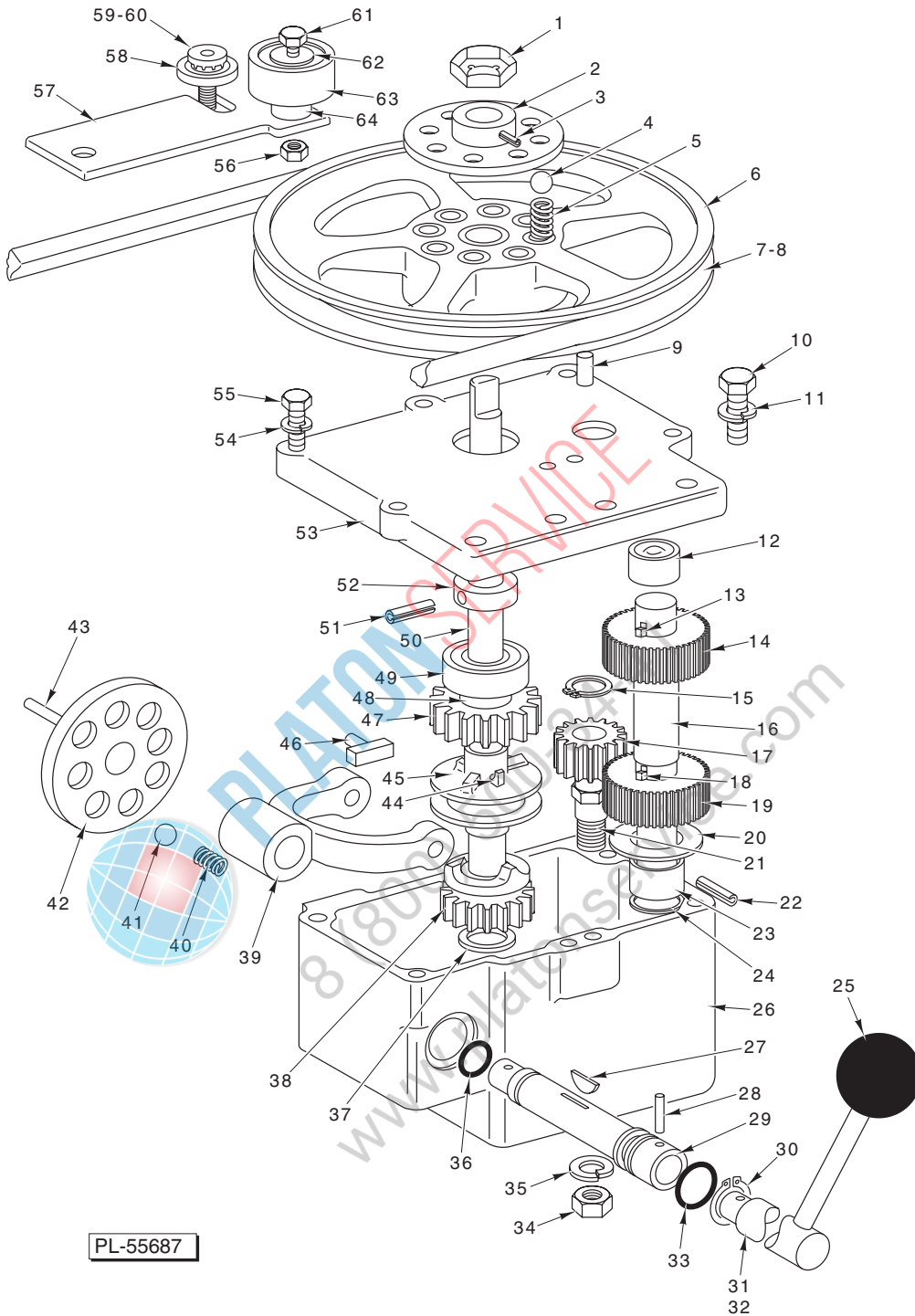

POWER BOWL LIFT UNIT

ILLUS.	PART NO.	NAME OF PART	AMT.
PL-55687			
1	NS-035-17	Special Nut ⁹ / ₁₆ -18 Palnut	1
2	00-067915	Hub & Detent Plate Assy.	1
3	PS-004-09	Spiral Pin ³ / ₁₆ Dia. x 1 Lg.	1
4	BA-002-18	Ball ³ / ₈ Dia.	8

POWER BOWL LIFT UNIT (Cont.)

ILLUS.	PART NO.	NAME OF PART	AMT.
5	00-064616	Spring – Slip Clutch Detent.....	8
6	00-479663	V-Pulley & Bushing Assy.	1
7	BV-013-18	V-Belt (ML-104687, ML-104694, & ML-104696).....	1
8	BV-013-17	V-Belt (ML-104674, ML-104686, & ML-104683).....	1
9	00-011800-00090	Dowel.....	2
10	SC-118-10	Cap Screw ³ / ₈ -16 x 1 Hex Hd.	2
11	WL-019-92	Lockwasher ³ / ₈ Light 2	
12	BN-002-09	Needle Bearing – Torrington (#M-1081)	1
13	KW-003-03	Key – Woodruff ¹ / ₈ x ¹ / ₂ Lg..... 1	
14	00-012699	Gear – Output (23T)..... 1	
15	RR-004-17	Retaining Ring..... 1	
16	00-064400	Shaft – Output..... 1	
17	00-064726	Idler Gear Assy. (15T)..... 1	
18	KW-003-03	Key – Woodruff ¹ / ₈ x ¹ / ₂ Lg..... 1	
19	00-012699	Gear – Output (23T)..... 1	
20	00-120407	Washer..... 1	
21	00-064523	Stud – Idler..... 1	
22	PS-004-15	Spiral Pin ¹ / ₄ Dia. x 1 ¹ / ₈ Lg..... 1	
23	BN-002-08	Needle Bearing – Torrington (#B-108)..... 1	
24	00-064643	Oil Seal – Bowl Lift..... 1	
25	00-060468	Knob – Gear Shift..... 1	
26	00-064395	Gear Box – Bowl Lift..... 1	
27	00-012430-00048	Key ³ / ₁₆ Sq. x ³ / ₄ Lg..... AR	
28	PS-005-13	Spiral Pin ³ / ₁₆ Dia. x ⁷ / ₈ Lg..... 1	
29	00-065567	Shaft – Yoke..... 1	
30	RR-004-06	Retaining Ring..... 1	
31	00-064727-00001	Lift Control Shaft & Handle Assy. (Painted)..... 1	
32	00-064727-00004	Lift Control Shaft & Handle Assy. (Chrome Plated)..... 1	
33	00-067500-00007	O-Ring..... 1	
34	NS-017-27	Jam Nut ¹ / ₂ -13 Hex..... 1	
35	WL-004-13	Lockwasher ¹ / ₂ Medium..... 1	
36	00-067500-00005	O-Ring..... 1	
37	00-064641	Bearing – Gear Box..... 1	
38	00-103642-00002	Lower Clutch Gear & Bearing Assy. (20T)..... 1	
39	00-064410	Yoke – Reversing..... 1	
40	00-007009	Spring – Detent (6 Lb.)..... 2	
41	BA-002-18	Ball ³ / ₈ Dia. 2	
42	00-067915	Hub & Detent Plate..... 1	
43	PS-004-09	Spiral Pin ³ / ₁₆ Dia. x 1 Lg..... 1	
44	00-064670	Key – (Special)..... 1	
45	00-477072	Clutch..... 1	
46	00-064403	Shoe – Clutch..... 2	
47	00-103641-00002	Upper Clutch Gear & Bearing Assy. (25T)..... 1	
48	WS-009-38	Washer..... 1	
49	BB-005-19	Ball Bearing (Fafnir #H202PP)..... 1	
50	00-438001	Shaft – Input..... 1	
51	RP-002-25	Roll Pin ¹ / ₈ Dia. x ⁷ / ₈ Lg..... 1	
52	00-064405	Collar – Input Shaft..... 1	
53	00-291045	Cover – Gear Box..... 1	
54	WL-003-37	Lockwasher ¹ / ₄ Medium..... 6	
55	SC-118-18	Cap Screw ¹ / ₄ -20 x ⁷ / ₈ Hex Hd. 6	
56	NS-013-11	Nut ⁵ / ₁₆ -18 Hex..... 1	
57	00-064508	Plate – Belt Tightener Mounting..... 1	
58	00-068839	Washer – Belt Tightener..... 1	
59	SC-061-04	Cap Screw ⁵ / ₁₆ -18 x 1 Soc. Flat Hd. 1	
60	WL-009-14	Lockwasher ⁵ / ₁₆ External Shakeproof..... 1	
61	00-064507	Special Screw..... 1	
62	WS-004-20	Washer..... 1	
63	00-122101	Belt Tightener Assy. 1	
64	00-111669	Bushing – Belt Tightener..... 1	
	00-064927-00003	Power Bowl Lift Assy. (Incls. Items 9 thru 29, 33, & 55)	

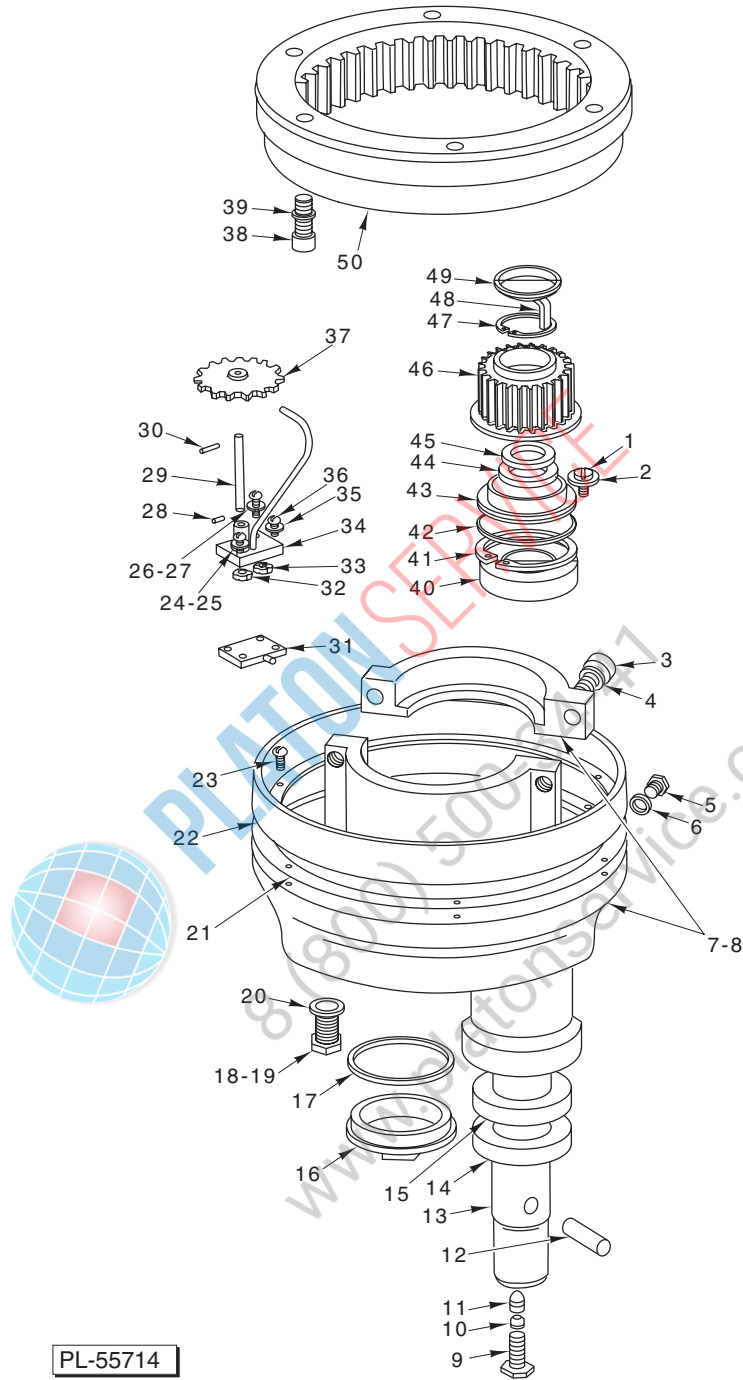

**PLANETARY UNIT
(M802 SERIES)**

**PLANETARY UNIT
(M802 SERIES)**

ILLUS. PL-55714	PART NO.	NAME OF PART	AMT.
1	SC-011-72	Mach. Screw 1/4-20 x 3/8 Fil. Hd.	2
2	WS-003-46	Washer	2
3	SC-087-45	Cap Screw 1/2-13 x 1 1/2 Soc. Fil. Hd.	2
4	WL-019-93	Lockwasher 1/2 High Collar	2
5	00-064465-00003	Plug – Oil Fill	1
6	WS-021-20	Washer	1
7	00-103645-00001	Planetary & Bearing Cap Assy. (Painted) (Incls. Items 3 & 4)	1
8	00-103645-00003	Planetary & Bearing Cap Assy. (Deluxe) (Incls. Items 3 & 4)	1
9	00-064723	Screw – Agitator Shaft	1
10	SC-047-41	Set Screw 3/8-16 x 3/8 Soc. Hdls., Cup Pt.	1
11	00-007744	Set Screw – Hdls., Cone Pt.	1
12	00-065717	Pin – Agitator Shaft	1
13	00-065749	Agitator Shaft Assy. (Incls. Items 9 thru 12)	1
14	00-024651	Seal – Planetary	1
15	BB-007-39	Ball Bearing (M.R.C. #207-SZZ)	1
16	00-437496-00004	Cap – Seal (Painted)	1
17	00-067500-00021	O-Ring	1
18	SC-037-23	Cap Screw 1/2-20 x 1 Hex Hd. (Painted) (Drain Plug for Planetary)	1
19	SC-037-26	Cap Screw 1/2-20 x 1 Hex Hd. (Deluxe) (Drain Plug for Planetary)	1
20	WS-021-21	Washer	1
21	00-064464	Gasket – Planetary	1
22	00-064478	Extension – Planetary	1
23	SC-009-70	Mach. Screw 6-32 x 1/4 Rd. Hd.	8
24	SC-060-87	Mach. Screw 10-32 x 3/4 Rd. Hd.	1
25	WL-003-22	Lockwasher #10 Light	1
26	SC-009-68	Mach. Screw 8-32 x 3/4 Rd. Hd.	1
27	WL-003-15	Lockwasher #8 Light	1
28	00-538772	Dowel 3/32 Dia. x 11/32 Lg.	1
29	00-186272	Shaft – Oil Pump	1
30	RP-002-08	Roll Pin 5/64 Dia. x 11/16 Lg.	1
31	00-064844	Bottom Plate Planetary Oil Pump Assy.	1
32	00-186270	Gear – Oil Pump (15T) (Slotted)	1
33	00-290277	Gear – Oil Pump (15T) (Slotted)	1
34	00-290232-00001	Planetary Oil Pump Assy.	1
35	WL-003-22	Lockwasher #10 Light	2
36	SC-081-17	Mach. Screw 10-32 x 1 Rd. Hd.	2
37	00-064614	Drive Gear Assy. (15T)	1
38	SC-040-27	Cap Screw 3/8-16 x 2 1/4 Soc. Fil. Hd.	6
39	WL-019-92	Lockwasher 3/8 High Collar	6
40	BB-006-36	Ball Bearing (M.R.C. #306-SZZ)	1
41	RR-004-24	Retaining Ring	1
42	00-067500-00021	O-Ring	1
43	00-073011	Baffle – Planetary Oil	1
44	00-065408	Spacer – Agitator Shaft	1
45	00-060768	Shim – Internal Pinion	AR
46	00-064732	Internal Pinion & Deflector Assy. (18T)	1
47	RR-005-08	Retaining Ring	1
48	00-074288	Key – Internal Pinion	1
49	00-060071	Cap – Oil Retaining	1
50	00-438121	Gear – Internal (59T)	1
	00-290232-00001	Planetary Oil Pump Assy. (Painted) (Incls. Items 24 thru 34 & 37)	1
	00-104532-00001	Planetary (Painted) (Incls. Items 1, 2, 3, 5, 6, 7, 13, 14, 15, 18, 20, & 40 thru 49)	1

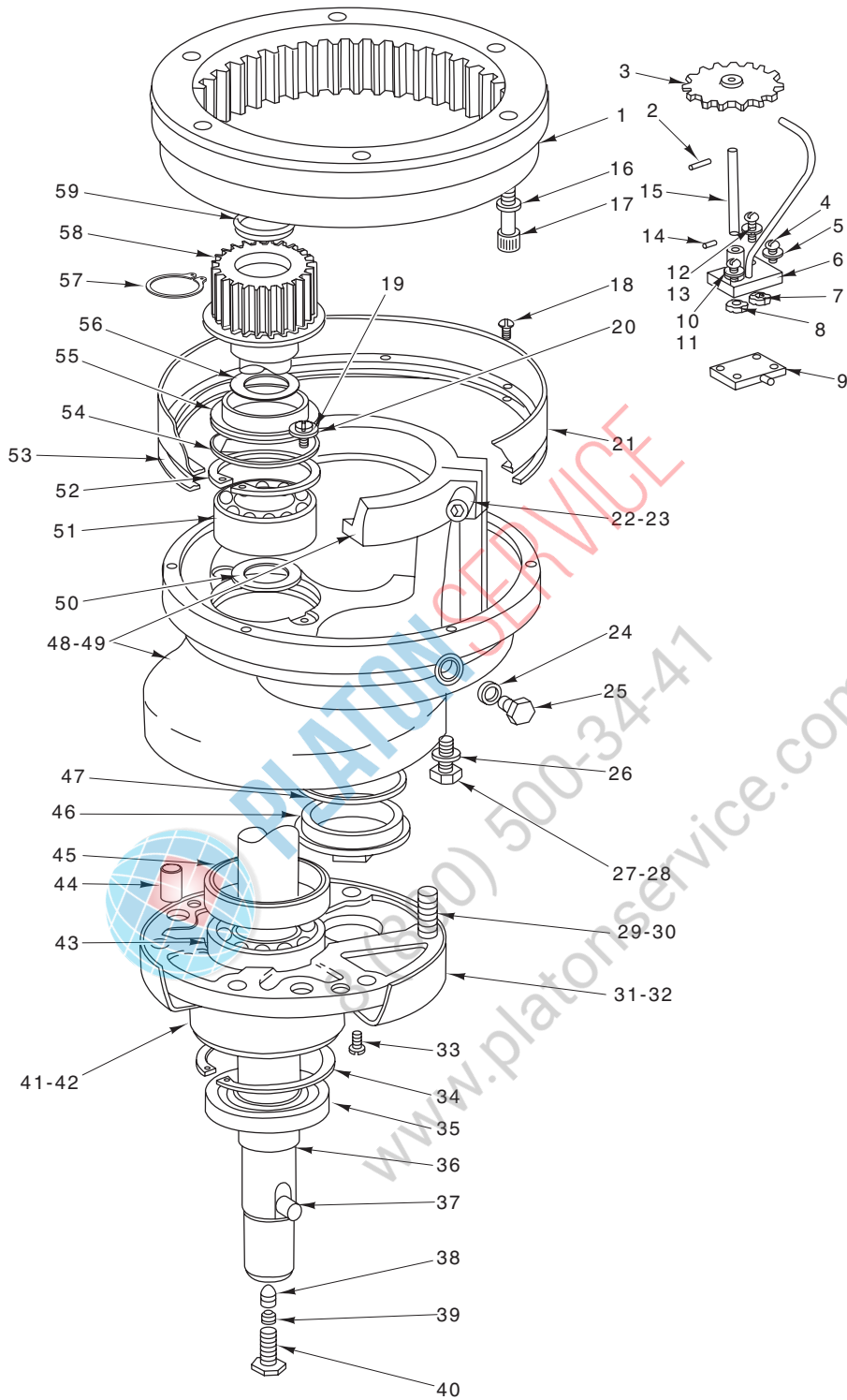

PL-55676

**PLANETARY UNIT
(V1401 SERIES)**

**PLANETARY UNIT
(V1401 SERIES)**

ILLUS. PL-55676	PART NO.	NAME OF PART	AMT.
1	00-438050	Gear – Internal	1
2	RP-002-08	Roll Pin ⁵ / ₆₄ Dia. x ¹¹ / ₁₆ Lg.	1
3	00-064614	Drive Gear Assy. (15T)	1
4	SC-081-17	Mach. Screw 10-32 x 1 Rd. Hd.	2
5	WL-003-22	Lockwasher #10 Light	2
6	00-290232-00001	Housing & Tubing Assy.	1
7	00-290277	Gear – Oil Pump (15T) (Slotted)	1
8	00-186270	Gear – Oil Pump (15T) (Slotted)	1
9	00-064844	Bottom Plate Planetary Oil Pump Assy.	1
10	SC-060-87	Mach. Screw 10-32 x ³ / ₄ Rd. Hd.	1
11	WL-003-22	Lockwasher #10 Light	1
12	SC-009-68	Mach. Screw 8-32 x ³ / ₄ Rd. Hd.	1
13	WL-003-15	Lockwasher #8 Light	1
14	00-538772	Dowel ³ / ₃₂ Dia. x ¹¹ / ₃₂ Lg.	1
15	00-186272	Shaft – Oil Pump	1
16	WL-004-06	Lockwasher ³ / ₈ High Collar	6
17	SC-040-28	Cap Screw ³ / ₈ -16 x 2 ¹ / ₂ Soc. Fil. Hd.	6
18	SC-009-70	Mach. Screw 6-32 x ¹ / ₄ Rd. Hd.	8
19	SC-011-72	Mach. Screw ¹ / ₄ -20 x ³ / ₈ Fil. Hd.	2
20	WS-003-46	Washer	2
21	00-064478	Extension – Planetary	1
22	SC-087-45	Cap Screw ¹ / ₂ -13 x 1 ¹ / ₂ Soc. Fil. Hd.	2
23	WL-019-93	Lockwasher ¹ / ₂ High Collar	2
24	WS-021-20	Washer	1
25	00-064465-00003	Plug – Oil Fill	1
26	WS-021-21	Washer	1
27	SC-037-23	Cap Screw ¹ / ₂ -20 x 1 Hex Hd. (Painted) (Drain Plug for Planetary)	1
28	SC-037-26	Cap Screw ¹ / ₂ -20 x 1 Hex Hd. (Deluxe) (Drain Plug for Planetary)	1
29	SC-120-28	Cap Screw ¹ / ₂ -13 x 2 Hex Hd.	6
30	WL-004-13	Lockwasher ¹ / ₂ Medium	6
31	00-068041-00002	Cover – Planetary Bearing Plate (Use on Machines With Bowl Scraper)	1
32	00-068041	Cover – Planetary Bearing Plate	1
33	00-080531	Screw – (Special) (Nylok)	2
34	RR-006-07	Retaining Ring	1
35	00-068045	Seal – Planetary	1
36	00-073821	Agitator Shaft Unit Assy. (Incls. Items 37 thru 40)	1
37	00-077757	Pin – Agitator Shaft	1
38	00-007744	Set Screw – Hdls., Cone Pt.	1
39	SC-047-41	Set Screw ³ / ₈ -16 x ³ / ₈ Soc. Hdls., Cup Pt.	1
40	00-064723	Screw – Agitator Shaft	1
41	00-067931-00001	Plate – Bearing (Painting)	1
42	00-067921-00003	Plate – Bearing (Deluxe)	1
43	BB-009-45	Ball Bearing (MRC #5210-KF)	1
44	00-011800-00237	Dowel	2
45	00-067903	Locator – Bearing	1
46	00-437496-00002	Cap – Seal (Painted)	1
47	00-067500-00021	O-Ring	1
48	00-110360-00001	Planetary & Bearing Cap Assy. (Painted) (Incls. Items 22 & 23)	1
49	00-110360-00003	Planetary & Bearing Cap Assy. (Deluxe) (Incls. Items 22 & 23)	1
50	00-067902	Spacer – Agitator Shaft	1
51	BB-009-44	Ball Bearing (MRC #5207-KF)	1
52	RR-004-24	Retaining Ring	1
53	00-064464	Gasket – Planetary	1
54	00-067500-00021	O-Ring	1
55	00-073011	Baffle – Planetary Oil	1
56	00-068277	Shim – Internal Pinion	AR
57	RR-006-08	Retaining Ring	1
58	00-067886	Internal Pinion & Oil Deflector Assy. (18T)	1
59	00-060071	Cap – Oil Retaining	1
	00-290232-00002	Planetary Oil Pump Assy. (Incls. Items 2, 3, & 5 thru 15)	1
	00-089050-00001	Planetary (Complete) (Painted)	1
	00-089050-00002	Planetary (Complete) (Deluxe)	1

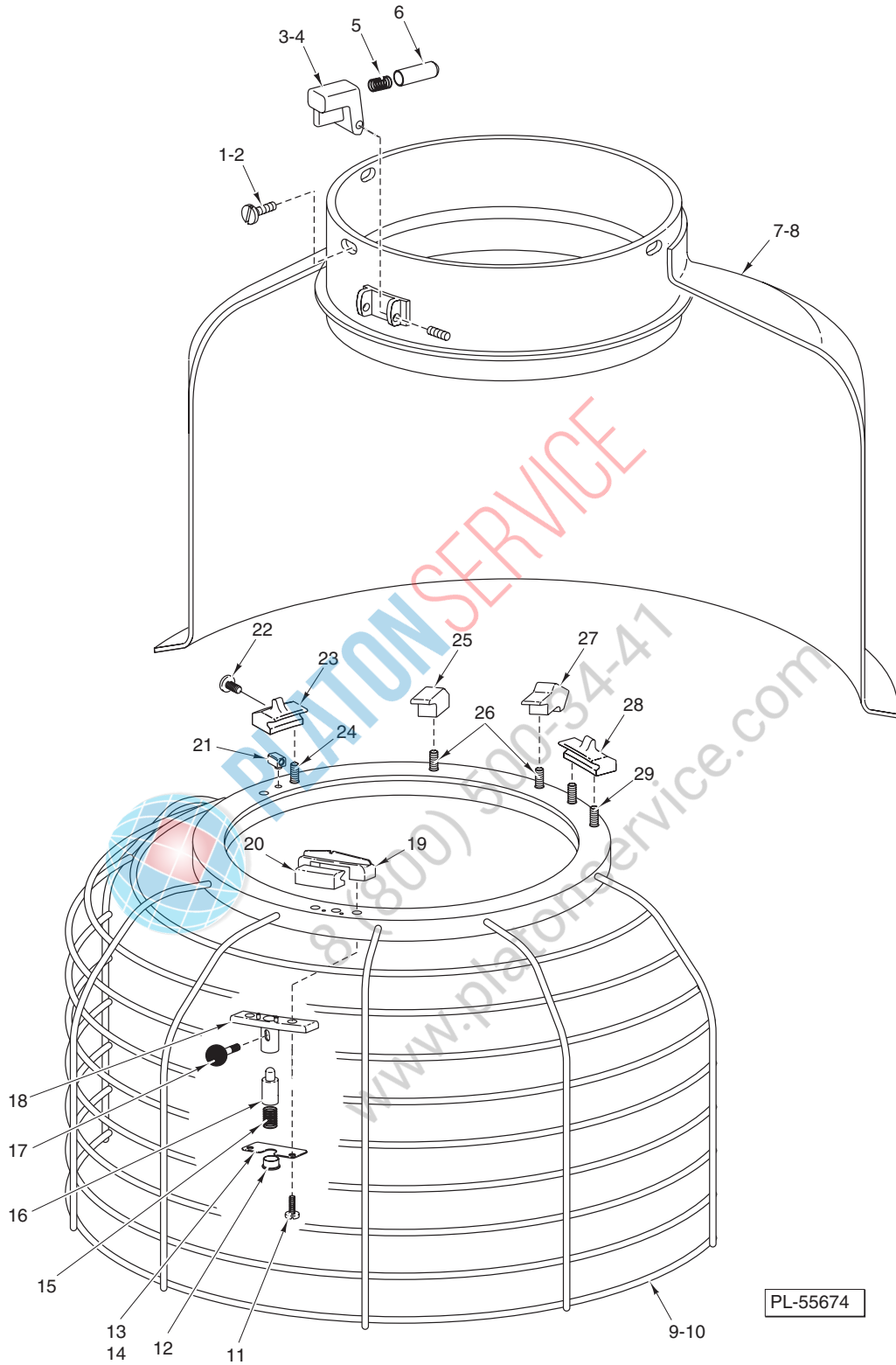

BOWL GUARD UNIT

BOWL GUARD UNIT

ILLUS. PL-55674	PART NO.	NAME OF PART	AMT.
1	SC-021-39	Mach. Screw 1/4-20 x 5/8 Rd. Hd. (ML-104687, ML-104694, & ML-104696)	3
2	SC-021-37	Mach. Screw 1/4-20 x 3/8 Rd. Hd. (ML-104674, ML-104686, & ML-104683)	3
3	00-479010	Latch – Cage Detent	1
4	00-479015	Set Screw (Special)	2
5	00-437446-00001	Spring – Cage Detent	1
6	00-437445	Plunger – Drip Cup	1
7	00-438118	Splash Guard Assy. (ML-104687 & ML-104696) (Incls. Items 3 thru 6)	1
8	00-438044	Splash Guard Assy. (ML-104674, ML-104686, & ML-104683) (Incls. Items 3 thru 6)	1
9	00-438120	Wire Cage Assy. (ML-104687, ML-104694, & ML-104696) (Incls. Items 11 thru 13 & 15 thru 29)	1
10	00-438049	Wire Cage Assy. (ML-104674, ML-104686, & ML-104683) (Incls. Items 11, 12, & 14 thru 29) ..	1
11	SC-122-46	Mach. Screw 1/4-20 x 3/4 Truss Hd. (Special)	2
12	00-438053	Plug – Plunger Housing	1
13	00-437691	Stop – Cage (ML-104687, ML-104694, & ML-104696)	1
14	00-438126	Stop – Cage (ML-104674, ML-104686, & ML-104683)	1
15	00-437446-00002	Spring – Cage On/Off	1
16	00-437432	Plunger	1
17	00-437436	Pin – Plunger	1
18	00-437447	Housing & Pin Assy.	1
19	00-437437-00002	Saddle – Shoe	1
20	00-437433-00001	Shoe – Saddle	1
21	00-437720	Key – Shoe	1
22	SC-122-44	Mach. Screw 8-32 x 3/8 Truss Hd. (Special)	1
23	00-437433-00003	Shoe – Adjustable	1
24	SC-122-45	Mach. Screw 1/4-20 x 3/8 Truss Hd. (Special)	2
25	00-438055	Bumper – Cage	1
26	SC-122-44	Mach. Screw 8-32 x 3/8 Truss Hd. (Special)	2
27	00-437442	Retainer – Magnet	1
28	00-437433-00002	Shoe – Fixed	1
29	SC-122-45	Mach. Screw 1/4-20 x 3/8 Truss Hd. (Special)	2

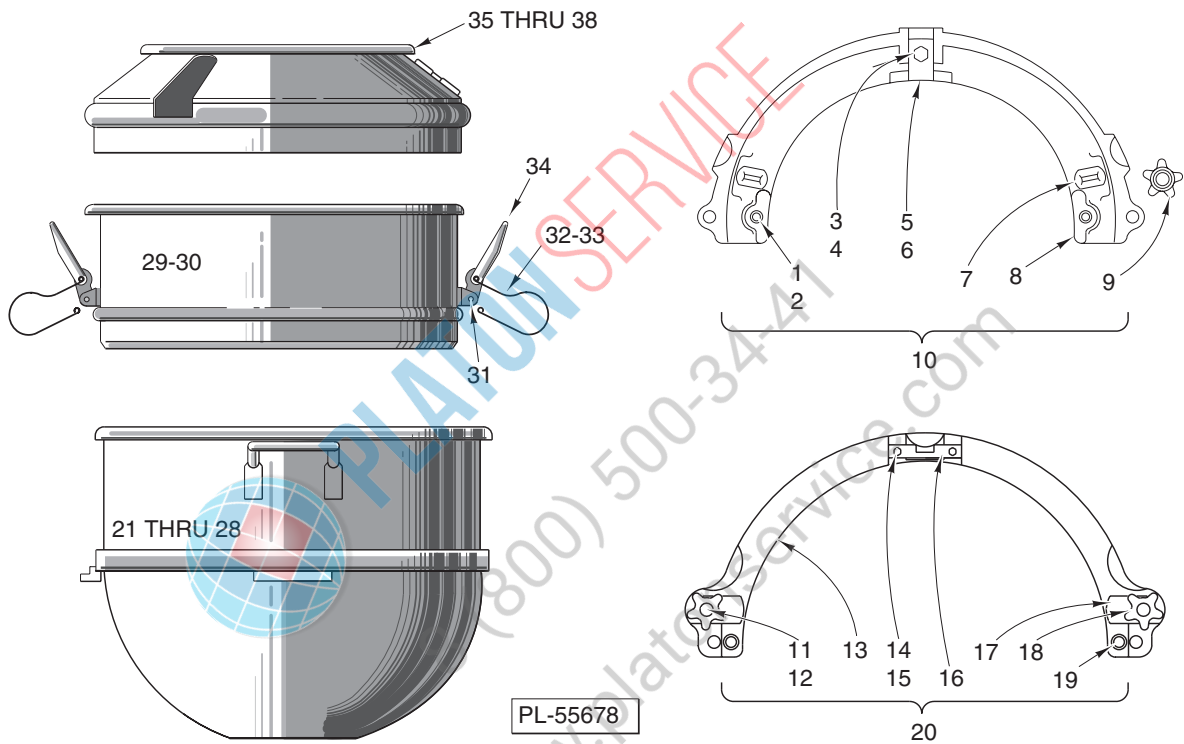

**BOWLS AND EQUIPMENT
(M802 SERIES)**

**BOWLS AND EQUIPMENT
(M802 SERIES)**

ILLUS.	PART NO.	NAME OF PART	AMT.
PL-55678			
1	WL-004-17	Lockwasher ⁵ / ₈ Light	2
2	00-007629-00002	Stud – Bowl Locating	2
3	SC-062-37	Cap Screw ¹ / ₂ -13 x 1 Hex Hd.	1
4	WL-004-11	Lockwasher ¹ / ₂ Light	1
5	00-007624-00001	Retainer – Bowl	1
6	00-111671	Shim (0.010 Thk.)	AR
7	00-008100-00001	Stud – Clamp	2
8	00-111165-00001	Adapter (80-40 Qt. & 80-30 Qt.) (Painted)	1
9	00-111268-00001	Knob – Clamp Stud (Painted)	2
10	00-024653-00001	Bowl Adapter Assy. (Tinned) (80-30 Qt.) (Pkg.) (Incls. Items 1 thru 9)	1
11	00-022196	Bolt – Bowl Lock	2
12	WL-004-11	Lockwasher ¹ / ₂ Medium	2
13	00-065791-00001	Adapter (80-60 Qt.) (Painted)	1
14	SC-037-88	Cap Screw ⁵ / ₁₆ -18 x 1 ¹ / ₂ Hex Hd.	2
15	WL-003-47	Lockwasher ⁵ / ₁₆ Medium	2
16	00-024289	Retainer – Bowl	1
17	00-065532-00001	Clamp – Bowl Adapter (Painted)	2
18	00-008101-00001	Knob – Clamp Stud (Tinned)	2
19	00-024300	Pin – Bowl Locating	2
20	00-061033-00001	Bowl Adapter Assy. (Tinned) (60-80 Qt.) (Pkg.) (Incls. Items 11 thru 19)	1
21	00-275690	Bowl – 80 Qt. (SST) (Pkg.)	1
22	00-275689	Bowl – 80 Qt. (Tinned) (Pkg.)	1
23	00-275688	Bowl – 60 Qt. (SST) (Pkg.)	1
24	00-275687	Bowl – 60 Qt. (Tinned) (Pkg.)	1
25	00-275686	Bowl – 40 Qt. (SST) (Pkg.)	1
26	00-295650	Bowl – 40 Qt. (Tinned) (Pkg.)	1
27	00-295648	Bowl – 30 Qt. (SST) (Pkg.)	1
28	00-275684	Bowl – 30 Qt. (Tinned) (Pkg.)	1
29	00-438104-00002	Extension – 80 Qt. Bowl (SST) (Flange Top Bowl) (Pkg.) (Incls. Items 31 thru 34)	1
30	00-438104-00004	Extension – 60 Qt. Bowl (SST) (Flange Top Bowl) (Pkg.) (Incls. Items 31 thru 34)	1
31	RP-002-35	Roll Pin ³ / ₁₆ Dia. x ⁵ / ₈ Lg. (For Items 29 & 30)	2
32	RP-003-22	Roll Pin ³ / ₁₆ Dia. x 1 ¹ / ₂ Lg. (For Items 29 & 30)	2
33	00-437636	Spring – Bowl Clamp (80 or 60 Qt.) (Flange Top Bowl) (For Items 29 & 30)	2
34	00-437586	Handle – Clamp (80 or 60 Qt.) (For Items 29 & 30)	2
35	00-438083	Splash Cover Assy. – (100 & 80 Qt.) (Pkg.)	1
36	00-438082	Splash Cover Assy. – (60 Qt.) (Pkg.)	1
37	00-438081	Splash Cover Assy. – (40 Qt.) (Pkg.)	1
38	00-438080	Splash Cover Assy. – (30 Qt.) (Pkg.)	1

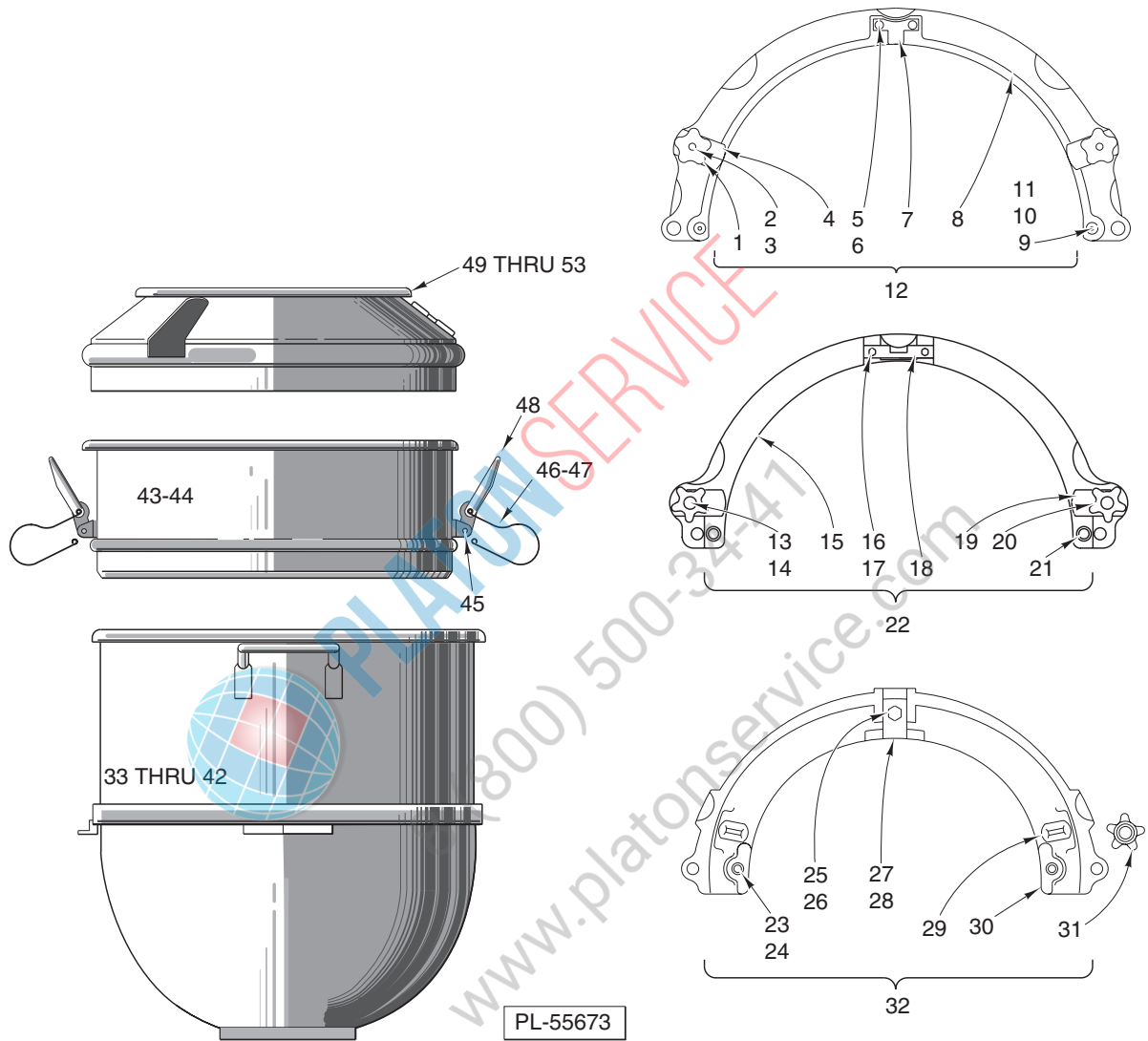

**BOWL AND EQUIPMENT
(V1401 SERIES)**

**BOWL AND EQUIPMENT
(V1401 SERIES)**

ILLUS. PL-55673	PART NO.	NAME OF PART	AMT.
1	00-008101-00001	Knob – Clamp Stud (Tinned)	2
2	00-022196	Bolt – Bowl Lock	2
3	WL-004-11	Lockwasher 1/2 Medium	2
4	00-065532-00001	Clamp – Bowl Adapter (Painted)	2
5	SC-036-40	Cap Screw 5/16-18 x 1 1/4 Hex Hd.	2
6	WL-003-47	Lockwasher 5/16 Medium	2
7	00-021020	Retainer – Bowl	1
8	00-065792	Adapter (140 to 80 Qt.)	1
9	00-062110	Stud – Bowl Locating	2
10	WL-004-04	Lockwasher 3/8 Light	2
11	NS-013-25	Nut 3/8-16 Hex	2
12	00-062111	80 Qt. Bowl Adapter Assy. (Pkg.) (Incls. Items 1 thru 11)	1
13	00-022196	Bolt – Bowl Lock	2
14	WL-004-11	Lockwasher 1/2 Medium	2
15	00-065791-00001	Adapter (80-60 Qt.) (Painted)	1
16	SC-037-88	Cap Screw 5/16-18 x 1 1/4 Hex Hd.	2
17	WL-003-47	Lockwasher 5/16 Medium	2
18	00-024289	Retainer – Bowl	1
19	00-065532-00001	Clamp – Bowl Adapter (Painted)	2
20	00-008101-00001	Knob – Clamp Stud (Tinned)	2
21	00-024300	Pin – Bowl Locating	2
22	00-061033-00001	60 Qt. Adapter Assy. Unit (Pkg.) (Incls. Items 13 thru 21)	1
23	00-007629-00002	Stud – Bowl Locating	2
24	WL-004-17	Lockwasher 5/8 Light	2
25	SC-062-37	Cap Screw 1/2-13 x 1 Hex Hd.	1
26	WL-004-11	Lockwasher 1/2 Medium	1
27	00-007624-00001	Retainer – Bowl	1
28	00-111671	Shim (0.010 Thk.)	AR
29	00-008100-00001	Stud – Clamp	2
30	00-111165-00001	Adapter (80-40 Qt. & 80-30 Qt.) (Painted)	1
31	00-111268-00001	Knob – Clamp Stud (Painted)	2
32	00-024653-00001	Bowl Adapter Assy. Unit (40 Qt.) (Pkg.) (Incls. Items 23 thru 31)	1
33	00-275692	Bowl – 140 Qt. (Pkg.)	1
34	00-295651	Bowl – 140 Qt. (SST) (Pkg.)	1
35	00-275689	Bowl – 80 Qt. (Tinned) (Pkg.)	1
36	00-275690	Bowl – 80 Qt. (SST) (Pkg.)	1
37	00-275687	Bowl – 60 Qt. (Tinned) (Pkg.)	1
38	00-275688	Bowl – 60 Qt. (SST) (Pkg.)	1
39	00-295650	Bowl – 40 Qt. (Tinned) (Pkg.)	1
40	00-275686	Bowl – 40 Qt. (SST) (Pkg.)	1
41	00-275684	Bowl – 30 Qt. (Tinned) (Pkg.)	1
42	00-295648	Bowl – 30 Qt. (SST) (Pkg.)	1
43	00-438104-00002	Extension Assy. (SST) (100 & 80 Qt. Flanged Top Bowl) (Pkg.) (Incls. Items 45 thru 48)	1
44	00-438104-00004	Extension Assy. (SST) (60 Qt. Flanged Top Bowl) (Pkg.) (Incls. Items 45 thru 48)	1
45	RP-002-35	Roll Pin 3/16 Dia. x 5/8 Lg.	2
46	00-437636	Spring – Clamp (Flange Top Bowl)	2
47	RP-003-22	Roll Pin 3/16 Dia. x 1 1/2 Lg.	2
48	00-437586	Handle – Clamp	2
49	00-438084	Splash Cover Assy. (140 Qt.) (Pkg.)	1
50	00-438083	Splash Cover Assy. (100 & 80 Qt.) (Pkg.)	1
51	00-438082	Splash Cover Assy. (60 Qt.) (Pkg.)	1
52	00-438081	Splash Cover Assy. (40 Qt.) (Pkg.)	1
53	00-438080	Splash Cover Assy. (30 Qt.) (Pkg.)	1

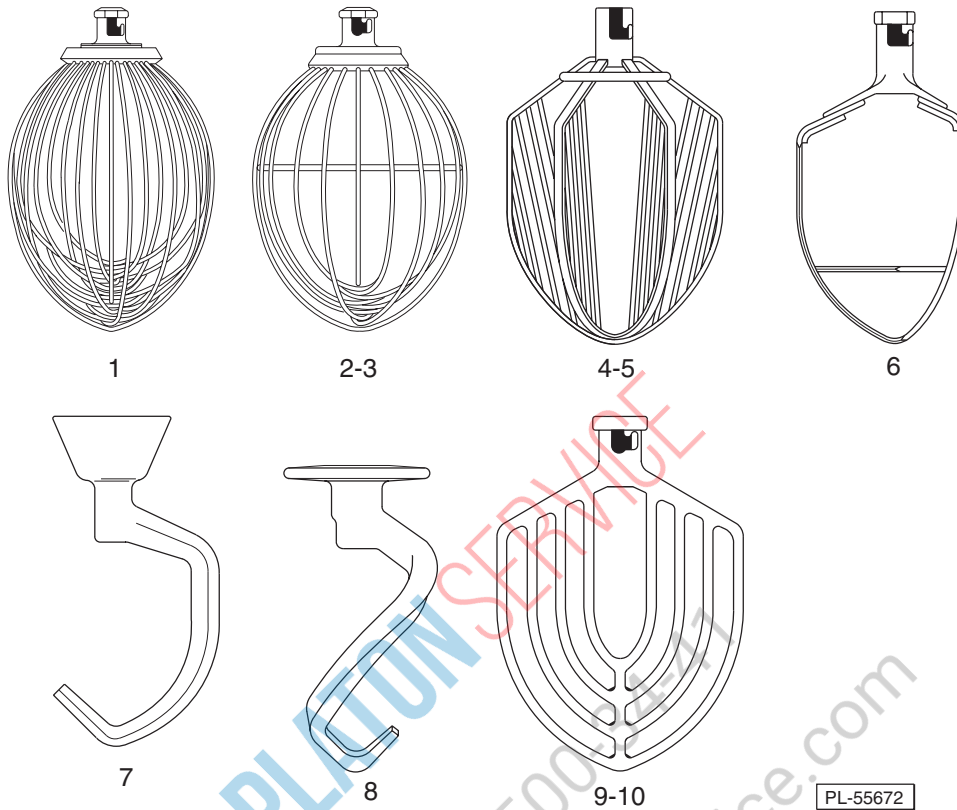

**AGITATORS
(M802 SERIES)**

ILLUS. PL-55672	PART NO.	PART NO.	PART NO.	PART NO.	NAME OF PART	AMT.
1	00-295149	00-295154	00-295157	00-439740	"D" Wire Whip (SST) (Pkg.)	1
2	---	---	00-295158	00-295162	"I" Wire Whip (SST) (Pkg.)	1
3	00-295150	00-295155	---	---	"I" Wire Whip (SST) (Pkg.)	1
4	00-295151	00-295156	00-295159	---	"C" Six Wing Whip (Tinned) (Pkg.)	1
5	---	---	---	00-295160	"C" Four Wing Whip (Tinned) (Pkg.)	1
6	00-275836	00-275865	00-275449	00-275972	"P" Pastry Knife (Tinned) (Pkg.)	1
7	---	00-295175	00-295176	00-275458	"E" Dough Arm (Alum.) (Pkg.)	1
8	00-437701	00-295174	---	---	"ED" Dough Arm (Spiral) (Alum.) (Pkg.)	1
9	00-295041	00-275886	00-295033	00-295034	"B" Flat Beater (SST) (Pkg.)	1
10	00-275448	00-275885	00-275447	00-275809	"B" Flat Beater (Alum.) (Pkg.)	1

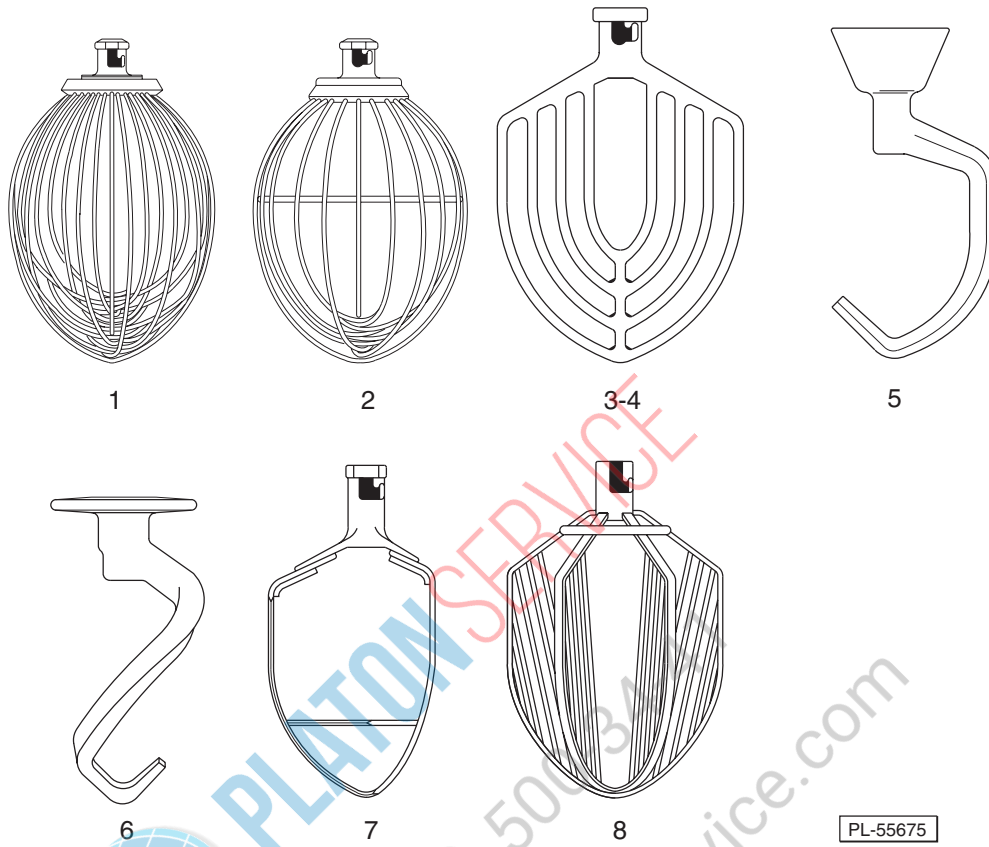

**AGITATORS
(V1401 SERIES)**

ILLUS. PL-55675	PART NO. 140 Qt.	PART NO. 80 Qt.	PART NO. 60 Qt.	PART NO. 40 Qt.	NAME OF PART	AMT.
1	00-295143	00-295149	00-295154	00-295157	"D" Wire Whip (SST) (Pkg.)	1
2	00-295144	00-295150	00-295155	00-295158	"I" Wire Whip (SST) (Pkg.)	1
3	00-275883	00-275448	00-275885	00-275447	"B" Flat Beater (Alum.) (Pkg.)	1
4	00-275884	00-295041	00-275886	00-295033	"B" Flat Beater (SST) (Pkg.)	1
5	---	---	00-295175	00-295176	"E" Dough Arm (Alum.) (Pkg.)	1
6	00-295131	00-437701	00-295174	---	"ED" Dough Arm (Alum.) (Pkg.)	1
7	00-295169	00-275836	00-275865	00-275449	"P" Pastry Knife (Tinned) (Pkg.)	1
8	00-295145	00-295151	00-295156	00-295159	"C" Six Wing Whip (Tinned) (Pkg.)	1



PLATON SERVICE

8 (800) 500-34-47

www.platonservice.com